

PAPER • OPEN ACCESS

Research of “influence area” parameters of the foundations arranged without soil

To cite this article: M L Zotsenko *et al* 2019 *IOP Conf. Ser.: Mater. Sci. Eng.* **708** 012076

View the [article online](#) for updates and enhancements.

Research of “influence area” parameters of the foundations arranged without soil

M L Zotsenko¹, Yu L Vynnykov^{1,2}, N M Pinchuk¹ and S M Manzhali¹

¹ Department of Architecture and construction Poltava National Technical Yuri Kondratyuk University, Pershotravnevyyi Avenue, 24, Poltava, 36011, Ukraine

² Email: vynnykov@ukr.net

Abstract. New relationships of shapes, sizes and properties formation for soils of the “influence area” of foundations and artificial bases, arranged without excavation, have been determined. The “influence area” parameters are decisive in assessing the stress-strain state of the system “base – foundation”. Field and laboratory methods of soil properties research of the “influence area” were improved: penetration; probing; rotational slip. A method of constructing the compaction area boundaries is considered, taking into account the shape, dimensions of the foundation cross-section and longitudinal profile, the type and properties of the base soil. For the first time, it is established that for soils with an angle of internal friction $\varphi < 25^\circ$, the boundaries of the compaction area and the “influence area” are close to each other. When $\varphi > 25^\circ$ the boundaries of the “influence area” exceed the boundaries of the compaction area as more, the more the angle of internal friction of the soil. The relationship between the volume of the leading well and the soil compaction area diameter was also determined.

1. Introduction

Foundations and artificial bases, arranged without excavation, have common characteristic feature – the formation during their arrangement, so-called, “influence area” in surrounding compressible soil and strengthening of it as a result [1]. This area, in the process of structure loading, works with it in interaction and determines the strength and deformability of the system “base – structure” [2]. The properties of the “influence area” are inclined to changes over time [3]. A detailed research of the all “influence area” parameters allows to solve objectively the problem of the bases and foundations of buildings and structures reliability [4]. At the same time the problem of strength balance for this system, which is directly related to the material consumption of construction, is solved [5].

“The influence area” is divided into sections [6]: I – dense shell from thin (3 – 15 mm) soil layers within the depth of the foundation immersion; II – compacted soil (in it the structure of the soil is broken, its density is higher than the initial one, and its dimensions and quality of soil compaction significantly influence on the nature of ‘settling – loading’ dependence for foundation); III – transitional, which is developed to the natural structure soil (stresses are still spreading in it, but no movement of soil particles occurs). The degree of soil properties change in the “influence area” depends from the base type and condition, the shape of the precast foundation (gear), efforts during the arrangement and maintenance of the foundations, etc. [7]. It is possible to evaluate soil within the compaction area by directly determining its density or mechanical properties [8]. The limits of the transitional boundary cannot be determined by such methods.



2. Purpose of the work

Therefore, for the purpose of the work, it is accepted to improve the research methods of the “influence area” soils properties and, based on this, establish new dependences of forms, sizes and properties of soils “influence area” formation for foundations, arranged without excavation.

3. Methodology and Research

For the research of compaction areas, which is formed during the arrangement of foundations, a penetration method [9, 10] was developed, it is based on the relationship between specific penetration resistance, porosity coefficient and soil moisture. Penetration is a method of assessing the physical and mechanical properties of soils by determining their resistance to dipping tips of various shapes and sizes. However, dipping the tip is carried out only to its height h_k . If the depth of the tip exceeds its height, this is called soil probing. Penetration testing of soils is carried out by steel conical tips with opening angle 30° . Specific penetration resistance R equal to the ratio of the penetration force to the square of the cone tip depth of immersion is taken as the characteristics of penetration tests.

$$R = P/h^2. \quad (1)$$

The probing is performed with an extended tapered tip when the ratio of the diameter of the cone to the diameter of the rod is 1.6 and more. With this ratio, without the exception (significant reduction) of friction on the lateral surface of the rods, conditions are created for the projection of soil into the cavity formed between the walls of the well and the bar. Cone soil resistance q_s is a probing parameter that is equal to the ratio of the sounding force to the area of the base of the cone

$$q_s = P/A. \quad (2)$$

The technique of the compaction area research by penetration method is within the expected limits of the “influence area” near the foundation, the soil is layer-by-layer removed and at different horizons, depths of the foundation are performed by penetration tests on the structures perpendicular to the foundation sides. Each point of penetration is precisely oriented in space relative to the axes of the foundation. At the same time, control samples are taken to determine the density and humidity of the soil in the laboratory. Fig. 1 shows a diagram of the sampling sites location and penetration tests points in a pyramidal pile with a cross section at the top 70×70 cm, 10×10 cm below and 2.0 m le, immersed in small quartz homogeneous sands of medium density, small water saturation.

The computation of the obtained data is performed in the following sequence. 1. Draw a contour of the foundation and a vertical section of the surrounding part of the base in scale, indicating the horizons of penetration tests. 2. For each horizon, a diagram of change in R with distance from the foundation (curve which ordinate decreases in the compaction zone and is constant outside it) is shown in Fig. 3. The boundary of the compaction zone is determined at the point where the curve R goes straight. For this, it is necessary to decide with what accuracy the specific penetration resistance at the experimental horizons outside the compaction zone is determined. If R exceeds $R_n + \sigma$ (R_n – for natural soil, σ – the standard deviation of the value R_n), this value corresponds to compacted soil.

A section of the space around the pyramidal pile with diagrams of R changes in the horizons is given in Fig. 2. To determine the standard deviation of R beyond the predicted area, compaction were taken from each of the four last points of each horizon penetration, total 168 values of R . In the calculations, the average value is 0.125 MPa at a standard deviation of ± 0.025 MPa. If the specific penetration resistance exceeds $R_y = 0.15$ MPa, the soil is considered to compacted ones. Determining the points with $R_y = 0.15$ MPa position on the graphs for each horizon, set the outline of the curve that limits the compaction area in the pile. It should be noted that in this example pyramidal pile was immersed in a uniform soil. When different layers of soil are located at the depth of the pile, their values are determined for each layer R_n, σ, R_y .

Similar tests were performed for the in-situ concrete pile in the punched hole (CPPH) with expansion at the bottom of the rammed crushed stone. Well of depth is 2.0 m, diameter - 0.5 m, volume of crushed stone in expansion – 2.0 m³. Soil – loess-like loam (plasticity index 0.12), semi-solid with a soil skeleton density is $\rho_d = 1.40 \text{ t/m}^3$. The section of the space around the pile with the drawing of changes R in the horizons are shown in Fig. 3.

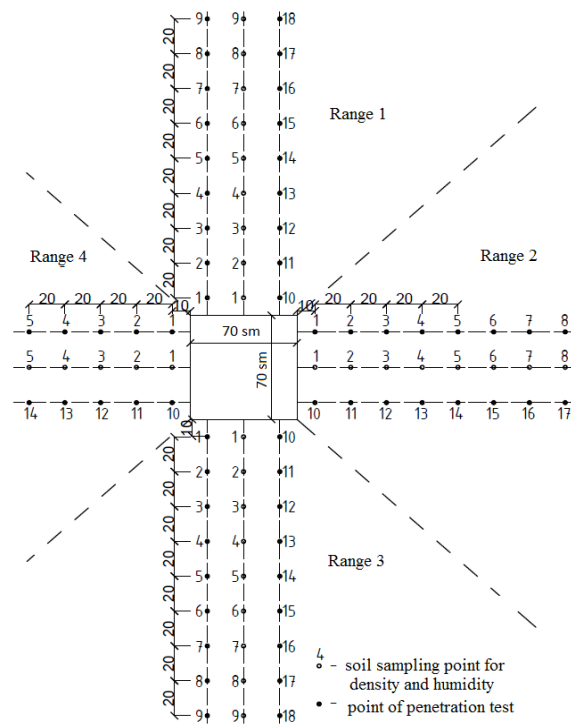

Figure 1. Scheme of soil sampling points and penetration tests locations

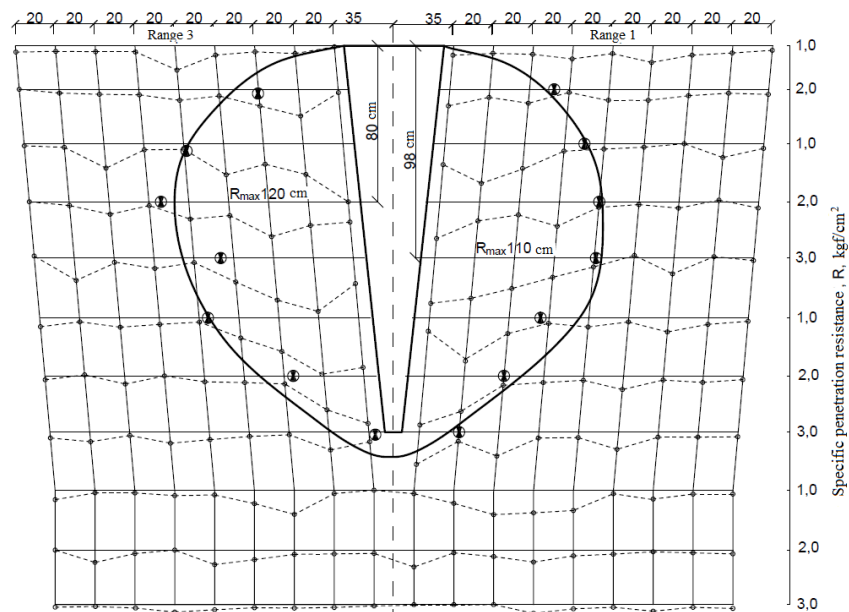

Figure 2. Determination of compaction areas boundaries in pyramidal pile by penetration

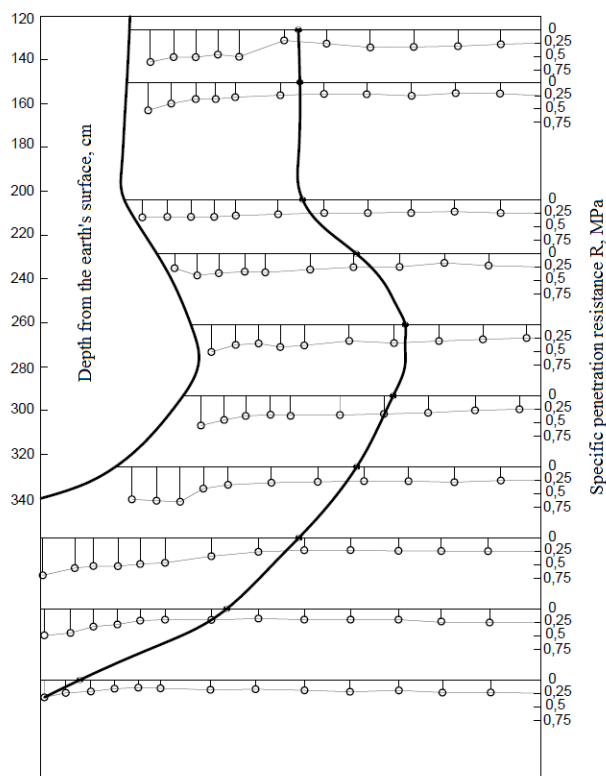

Figure 3. Determination of the soil compaction area boundaries in the CPPH by the penetration method

The average value of soil penetration resistance is $R_n = 0.266$ MPa at a standard deviation of $\sigma = \pm 0.02$ MPa. These parameters are determined by the results of 86 separate penetration tests.

The research of the compaction area for various foundations, arranged without excavation, in a wide range of engineering and geological conditions has been completed. Due to its high sensitivity, the penetration method reliably fixes changes in the soil's mechanical properties within the compaction area, significantly reduce and even eliminate soil sampling for density and humidity tests. The ability to obtain a large number of specific penetration resistance definitions at limited sites allows to use methods of mathematical statistics in analyzes and obtain reliable results. Nevertheless, there is a certain complexity of the method due to the need for the passing the pits and penetration by hand penetrometer. There are also difficulties in the study of soils below the groundwater level. To eliminate these shortcomings and preserve the advantages of the penetration method, a technique for determining the parameters of the soil compaction area in the bases according to the data of static probing has been developed.

Figure 4 shows a section of a pyramidal pile and surrounding soil with diagrams of cone soil resistance variation over unconditionally selected horizons. The pyramidal pile is 70×70 cm in section, 10×10 cm in bottom part and 2.0 m in length, and is immersed in small, quartz homogeneous sands of medium density, low water saturation.

The inflection points of the distribution curves q_s are calculated by value $q_{sy} = q_{sn} + \sigma$ within the critical probing depth. The use of the probing method with an expanded conical tip in the study of the compaction area has allowed to significantly reduce the complexity of work, use modern mechanized equipment, exclude excavation, to make investigation below the groundwater level. The probing method should be attributed to non-destructive research methods, it can be applied to study the

compaction area of existing buildings without causing damages. This cannot be said about the methods of penetration and sampling at depth for density-moisture in the wells.

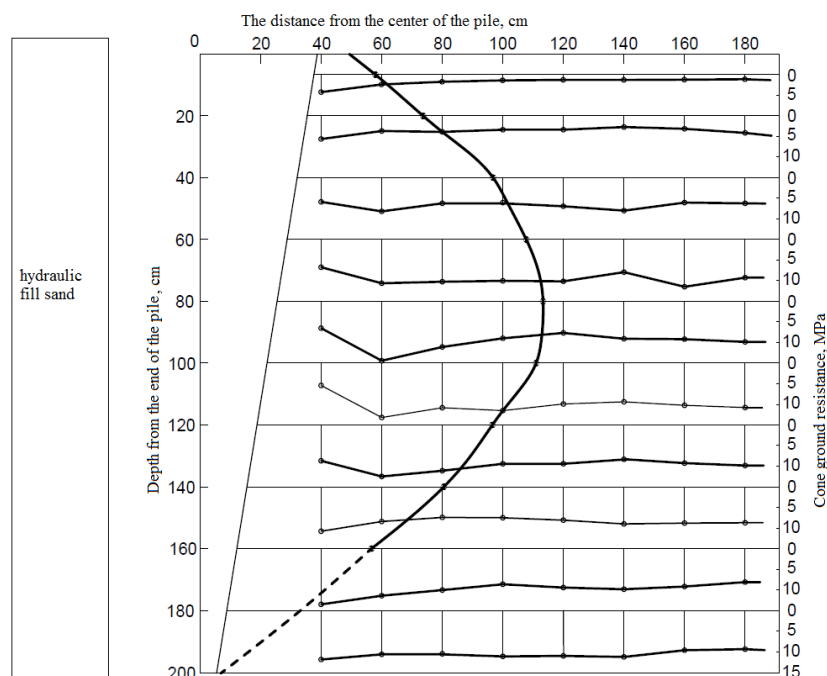

Figure 4. Determination of the compaction area boundaries in the pyramidal pile by the probing method

Investigation of the compaction area by penetration and probing methods for various foundations (prismatic, pyramidal, three-beam hammer piles and blocks; foundations in broken down pits, drilled wells with extension in the lower part; and double-cone barrel, etc.) is done. In total, the compaction areas have been investigated on more than 150 foundations in different soil conditions. The obtained experimental data allowed us to establish relations of “influence area” formation in the listed foundations. Fig. 5 shows the structure of the “influence area” of the pyramidal piles. Within it, three components are distinguished: a – pushing out; b – compaction; c – transitional.

In plan, these sections have a shape similar to concentric circles. However, in the pyramidal piles in plan, the compaction area is slightly flattened at the edges and reaches a maximum radius near the center of the faces. The radius of the compaction area at the edges of the pyramidal pile is $0.1b_p$ less than the radius near the face center (with variation coefficient $\nu=0.08$). For practical purposes, it is customary to consider the compaction area circular in plan with a radius centered on the pile edge.

In laboratory research the method of determining the boundaries of the spreading area of stresses in the soil – “influence area” has been developed. It is based on the principle of invariance of the specific resistance of penetration, which is disturbed by the concentration of stresses in the soil near the obstacle. Depending on the ratio of the concentrically located circler, diameters and the diameters of the conical tip part on their upper edges uniquely determined at what depth of the sample is fixed effect achieved. In total in this series, there were 55 direct determinations of the “influence area” diameter. According to the results of the displacement tests, the range of internal friction angle is $\varphi = 12 - 26^\circ$. In Fig. 6, these data are represented by part of curve 2 in the corresponding angle range of internal soil friction. In this figure, the results of the experiments are represented by part of curve 2 in the range of the angle of internal friction values $\varphi = 22 - 38^\circ$. Each test point of this part of the curve is determined according to five parallel tests. The same figure shows curve 1 established to the pyramidal piles according to the field tests results of the compaction area by penetration and

probing methods. In this case, the condition $C=D$ is accepted (Fig. 5). The corresponding equation is (with correlation coefficient $r = 0.99$ and variation coefficient $v = 0.024$)

$$C/b_p = 1.39 + \exp(0.024 \times \varphi^\circ) \tag{3}$$

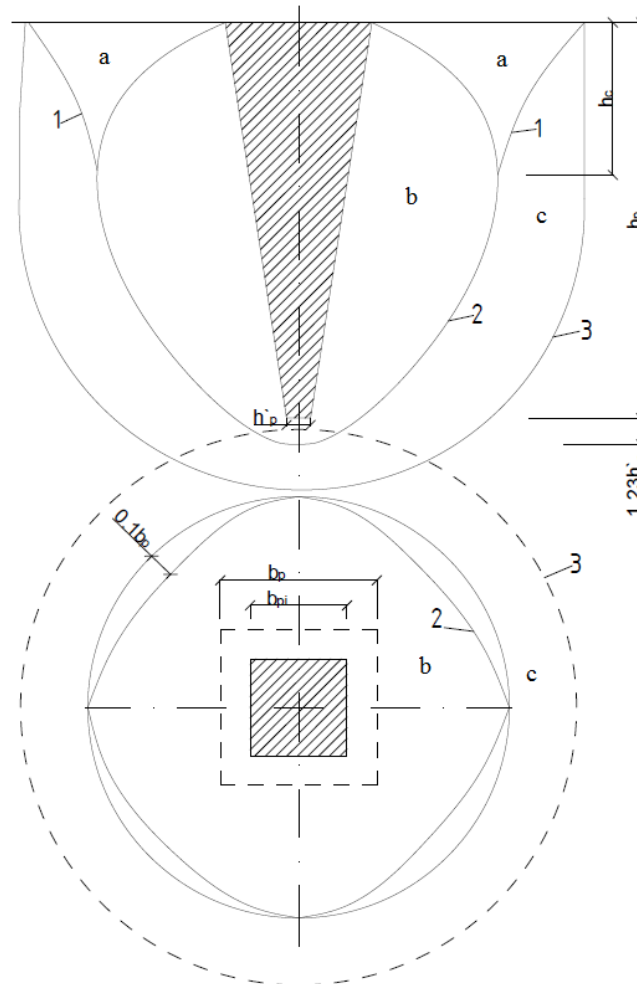

Figure 5. The structure of the “influence area” of the pyramidal pile, areas: a – pushing out; b – compaction; c – transitional; borders of areas: 1 – pushing out; 2 – compaction (D); 3 – influence (C)

In particular, it was found that for soils with an angle of internal friction $\varphi < 25^\circ$ (three-phase clayey, loose sand) the boundaries of the compaction area D and the “influence area” C are close to each other (Fig. 6). If the angle $\varphi > 25^\circ$, the boundaries of the “influence area” exceed the boundaries of the compaction area, as bigger as internal soil friction angle bigger (Fig. 6).

The arrangement of the leading wells in the soil facilitates the immersion of piles, but the lead-up worsens the conditions of the compaction area formation when the foundations are immersed (their bearing capacity thus decreases). To study the effect of the leading well volume on the conditions of compaction area formation on the site, composed of semi-solid loam, immersed 13 pyramidal piles of two sizes in different leading wells. According to the parameters measurements of the leading wells and compaction areas it is established that with increasing volume of the well in the compaction area, the average value of the density of the soil skeleton decreases and, accordingly, the specific

penetration resistance R . The relationship between the ratio of the leading well volume and the pile V_l/V_p and the ratio of the compaction area diameter to the pile diameter D/b_p ($r=0.979$, $\nu=0.023$)

$$D/b_p = 2.5 - 0.92 [V_l/V_p]^{0.7} \quad (4)$$

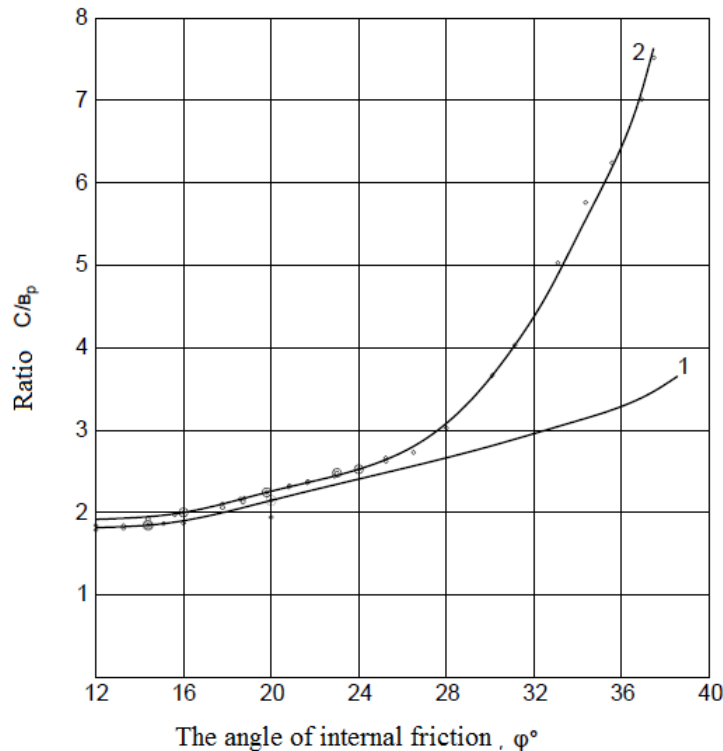

Figure 6. Graph of the ratio C/b_p , from the angle of internal soil friction φ curves to determine the diameters: 1 – compaction area; 2 – “influence area”

From the bearing capacity point of view, the effect of leading during the foundation immersion without removing the soil is negative. Sometimes it is necessary to place such foundations at a distance less than acceptable. Then by equation (4) it is possible to accept the volume of the leading well, which will reduce the compaction area diameter.

4. Conclusions

1. When the foundations construct without excavation are immersed, the so-called “influence area” is formed, within which the natural structure of the soil is changed. Within the “influence area” in which the compaction area is allocated, the particles have moved and acquired a denser state when the structure is failed, and a transitional section in which only a partial change of the soil structure has occurred without moving the particles. The study of the “influence area” parameters is essential for the bases calculation of such foundations by the limit states.

2. Existing methods of the “influence area” investigation: fixing of horizontal deformation and vertical marks; sampling for soil density and humidity – does not allow to obtain the correct quantitative parameters of this zone. A penetration method for determining the compaction area boundaries at the foundations basis, arranged without excavation, has been developed. It is based on the dependence between penetration resistance, density and soil moisture of the natural structure, with

constant indicative characteristics. The manufacturing application of the method in the research of soil compaction area proved its manufacturability, high accuracy and reliability.

3. For conditions where it is not possible to dig a pit for investigation the “influence area”, a method of probing tests was developed and put into practice to evaluate the parameters of the soil compaction area. Using extended conical tip, which creates a cavity between the rod and the wall of the well during the probing process. This allows during the probing keep the scheme of soil destruction unchanged and to record single-valued changes in its mechanical parameters within the area of compaction. As a research result of the compaction area parameters for more than 150 foundations, a method of constructing the compaction area boundaries has been developed, which takes into account the shape, dimensions of the cross-section and longitudinal profile of the foundation, the type and properties of the base soil.

4. In laboratory researches, using a special device, a technique for determining the boundaries of the area of stresses distribution in the soil – “influence area” was developed. The technique is based on the principle of invariance of the specific penetration resistance, which is broken if the stress concentration in the soil near the obstacle. The dimensions of the “influence area” have been studied over a wide range of angles of internal soil friction $\varphi = 12 - 38^\circ$. For the first time was invented that for soils with an angle of internal friction $\varphi < 25^\circ$ (three-phase clayey, loose sands), the boundaries of the compaction area and the “influence area” are close to each other. If the angle $\varphi > 25^\circ$ the “influence area” boundary exceeds the compaction area boundaries of the section, as bigger as bigger the angle of internal friction of the soil.

5. Foundations immersion in leading wells reduces labor costs, but reduces their bearing capacity by reducing the size and quality of the compaction area. The dependence between the volume of the leading well and the diameter of the soil compaction area was determined.

References

- [1] Briaud J-L 2013 *Geotechnical Engineering: Unsaturated and Saturated Soils* (Canada New Jersey: Wiley) 1022
- [2] Fleming K, Weltman A, Randolph M and Elson K 2008 *Piling Engineering* (London and New York: Taylor and Francis) 398
- [3] Seed R and Duncan J 1986 Fe Analyses: Compaction – Induced Stresses and Deformations *J. of Geotechnical Eng.* **112(1)** 23–43
- [4] Zotsenko M L and Vynnykov Yu L 2019 *Foundations, Arranged without Soil Excavation: Monograph* (Poltava: PolNTU) 346
- [5] Manjriker A and Gunarante I 2006 *Foundation Engineering* (New York: Taylor and Francis) 608
- [6] Zotsenko N L and Vinnikov Y L 2016 Long-Term Settlement of Buildings Erected on Driven Cast-In-Situ Piles in Loess Soil *Soil Mechanics and Foundation Engineering* **53 (3)** (New York: Springer Science+Business Media) 189–195
- [7] Kryvosheiev P, Farenjuk G and Tytarenko V 2017 Innovative projects in difficult soil conditions using artificial foundation and base, arranged without soil excavation *Proc. of the 19th Intern. Conf. on Soil Mechanics and Geotechnical Engineering* (Korea, Seoul: COEX) 3007–3010
- [8] Zotsenko N L, Vinnikov Y L, Kovalenko V I and Omelchenko P N 1989 Determination of shape and dimensions of compacted soil widenings and zones in punched holes *Soil Mechanics and Foundation Engineering* **5** (New York: Springer Science+Business Media) 177–181
- [9] Mechi J. 2013 *Geotechnical Engineering Examples and Solutions Using the Cavity Expanding Theory* (Budapest: Hungarian Geotechnical Society) 221
- [10] Sturm H 2013 The tip resistance in layered soils during static penetration *Proc. of the 18th Intern. Conf. on Soil Mechanics and Geotechnical Engineering* (Paris) 817 – 820