



# Neural Network Technology of the Financial and Economic Model Synthesis of Production as the Fragment of the Economy Digitalization

Sergei Alyoshin<sup>1</sup>, Elena Borodina<sup>2\*</sup>, Alla Haffiak<sup>3</sup>, Oleksandr Nosach<sup>4</sup>

<sup>1</sup>Poltava National Technical Yuri Kondratyuk University

<sup>2</sup>Poltava National Technical Yuri Kondratyuk University

<sup>3</sup>Poltava National Technical Yuri Kondratyuk University

<sup>4</sup>Poltava National Technical Yuri Kondratyuk University

\*Corresponding author E-mail: lena\_borodina@ukr.net

## Abstract

The purpose of the article is to develop a technology for designing neural network models for automatic monitoring of the tax burden to achieve the optimal balance between the possibility of developing a successful business and sufficient filling of the regional budget. A multi-layer perceptron and a back-propagation algorithm were applied for the research as well as a neural control technology. The automation of the process of determining the elements of the gradient vector was produced in implementing traditional method of the back-propagation of error by using neural control technology. For the first time, a solution to optimize the fiscally-tax burden (FTB) of the region has proposed with the application of the back-propagation algorithm. Using the proposed methodology a software tool will be created for the transition to an automatic system for optimal management of the economy.

**Keywords:** digitalization, fiscal and tax burden, neural network, neural network optimization, regional economy.

## 1. Introduction

In modern conditions the formation of the digital economy is a complex task of transition to a new technological level due to the introduction of information and telecommunication technologies at all stages of the value added chain. The main task of this process is obvious which is increasing the competitiveness and efficiency of the economy, developing its commodity potential, and improving the quality of consumer satisfaction of citizens. Deep digitalization involves introduction into production and management of new information technologies (nanotechnology, microbiology, artificial intelligence, total computer communications, etc.), which provide solution of the task of automating the control and management of the entire production process [1-3].

The problem is that a modern manufacturing plant belongs to a class of complex systems [1]. The term "complex system" is understood to mean an entity that has input factors and high-dimensional output states with poorly formalized, fuzzy relationships and a high degree of priori uncertainty [2]. The high dimensionality of factors and states, poorly formalized and unclear relationships, the presence of a human factor create a high degree of uncertainty in the production process, which does not allow making optimal decisions on control and management based on current input data. It is this feature that does not allow formalizing production in full and algorithmizing all financial and economic chains from investments to storage and sale of products.

However, full automation, robotization and intellectualization of production is the imperative of time [1,4,5]. The main prize of market competition is the possibility of extracting intellectual rent, obtained due to technological superiority, protected by intellectual

property rights and allowing having additional profit as a result of achieving greater production efficiency or higher product quality. In pursuit of this technological superiority for a manufacturing enterprise, the key task is to synthesize an adequate mathematical model of the enterprise, which will ensure the application of optimal decision rules and allow implementing instrumentally all the complex of control and management procedures in automatic mode [6,7].

This is facilitated by the availability of clear and tested by practice criteria for the quality of production and providing them with informative factors. Then using the modeling technology of complex systems [1,4], the task of modeling the financial and economic activity of the research object can be reduced to solving the problem of nonlinear optimization in the multidimensional space of factors and high-dimensional states [5]. At the same time, it is necessary to highlight the key quality criteria expertly, to put them in line with the values of the supporting factors on historical examples (retrospective data), and to establish and record rigorous analytical links through the forced learning of neural network models in a retrospective sample of practical examples [3].

Thus, the subject expert describes the task at the verbal level in terms of the financial and economic paradigm, and the specialist in information technologies deals with the formalization of the task and its instrumental solution.

As shown in [1, 6], it is expedient to apply intellectual procedures for data analysis on the basis of artificial neural networks for objects of the investigated type.

This choice of analytical tools is conditioned by undeniable and important advantages for practical use:

– neural networks are adaptive learning systems that extract in-

formation from real processes by examples, which are difficult to dynamically simulate, and frequently it is impossible, because they often contain a significant array of hidden, uncontrolled, incomplete and noisy parameters and mutual connections between them;

- their use makes it possible to solve problems that are difficult or impossible to solve by using traditional methods due to the absence of formalized mathematical descriptions of the functioning processes;
- they have an associative memory and in the course of the work they accumulate and generalize information, from which their effectiveness increases with time;
- their use is based on training the neural network to extract information from the experimental data, which ensures the objectivity of the results and increases their reliability.

In addition, modern software platforms (NeuroLand, Matlab, Statistica, etc.) allow us to design quickly a neural network environment and implement a wide class of architectures of neural networks with various complexity and rules for modifying weights in the process of compulsory training. At the same time, the use of artificial intelligence technology in managing complex objects requires taking into account specific features of each subject area, including a manufacturing enterprise with a specific set of indicators, criteria, factors and relationships between them. This fact reveals the need to adapt a set of standard options (preprocessing, organization of homogeneous subsets, factor analysis, input sensitivity, classification, forecasting, etc.) of the corresponding package of technical analysis to a specific field of study.

Domestic and foreign scientists have studied the problem, in particular: S. Khaikin, R. Hecht-Nielsen, T. Kohonen, etc., who were engaged in the development, theoretical justification and introduction of information technologies for the digitalization of the economy [4,5,6]. They examined the following:

- basic principles and methods of applied theory of artificial intelligence in social and technical systems;
- constructive approaches to design and modeling of complex social and production facilities;
- applied theory of management of social and industrial enterprises;
- the concept of applying the systems of analysis and control for high-risk objects;
- methods and algorithms of multilevel differential diagnostics in various subject areas;
- algorithmic and software products for operational multi-factor data analysis in the tasks of classification, prediction and adaptation of inputs to object states;
- complex qualimetry of basic processes of objects with different orientation.

At the same time, a full-scale, comprehensive and effective software base for automation of monitoring and management of the financial and economic activities of a production enterprise has not been found in the literature. The situation requires creating productive technologies and software for constructing models that automating the processes of recognition of the object state, predict the dynamics of behavior of the key markers and the selection of optimal control factors to ensure a controlled financial and economic climate at the enterprise by establishing deterministic relationships of criteria, states, factors based on intelligent technologies [4, 5].

The objective of the study is develop a technology for constructing a productive ensemble of neural network models for automatic monitoring and management of the financial and economic state of the facility (FESO) and for the productive search for an optimal ratio of input factors and its target states. The final product is the neural network models for recognizing the actual states and finding a set of input factors in which the criteria of the financial and economic state of the object take the required values and are kept within predetermined limits as the external influences change.

## 2. Formulation of the problem

It is necessary to describe the state of the FESO as a class in the language of its informative features, to find analytical maps of the input data vector to the result of estimating its actual state and to ensure a strictly deterministic functional influence of this vector on the target state of the object.

Formally, the problem is reduced to solving the problem of class recognition which can be performed in its two forms: direct and reverse. The direct problem estimates the current state of the object, and the reverse one deals with adaptation of the input data vector to the required state of the FESO.

In general, the signs of the behavior of the FESO and the number of classes are vector quantities:

$$|Y(t) = F | X(t)|, \quad (1)$$

where  $Y(t)$  is the class number of the FESO state class;  $X(t)$  is the vector of current values of input factors-signs;  $F$  is the functional of converting an array of input characteristics into a class number. The task of adapting the input vector to the required state of the FESO is to find the optimal set of input factor vector  $X_0(t)$ , corresponding to the target state vector  $Y_0(t)$  FNN FESO.

This process can be formally represented by a procedure:

$$F_0 : Y_0(t) \rightarrow X_0(t), \quad (2)$$

where  $Y_0(t)$  – target state vector of the object;  $X_0(t)$  – vector of adapted values of input attributes;  $F_0$  – the productive functional of modifying the array of current input factors to the desired set adequate to the target state.

The implementation of the algorithm (2) allows us to find the optimal set of input factors as a sequential solution of the direct and inverse problem of recognition of FESO states.

The solution of the inverse problem in the neural network format ensures finding of such signal values at the input of the trained network, under which the output state corresponding to the desired class is reached.

The classification (1) proposes to use the trained artificial neural network with back propagation of the error as a tool for automatic state recognition [6].

The search for input factors of FESO, which correspond to its target state, is proposed to put the technology of adapting inputs to the required state on the basis of the principles of neural control [7]. As a simulation tool, the environment simulator of the StatSoft environment was chosen.

It seems reasonable to justify the functioning of FESO as a realization of a set of basic functions that are implemented by continuous models, and the moments of making decisions about its current state, the forecast of behavior dynamics and the choice of control factors for achieving the target state are discrete. Proceeding from the fact that the decision-making in the FESO analysis is based on two system-forming processes, the modeling problem is formalized by the expression:

$$\begin{aligned} &Sup K_E(S, P, X, T_k), \\ &\Delta T \leq \Delta T_0, \\ &\delta \leq \delta_0, \end{aligned} \quad (3)$$

where  $s \in S, S$  is a set of current conditions of FESO;  $p \in P, P$  is a set of forecasts of the dynamics of the FESO states;  $x \in X, X$  – set of input factors of the FESO;  $T_k, k \in \{0,1,2,\dots\}$  are moments of decision-making time;  $K_E$  is a criterion for the productivity of the solution;  $\Delta T, \delta_0$  is the allowable time interval for decision making

and the required degree of adequacy of the model, respectively. Basic FESO processes that require formalization and modeling are presented in Fig. 1.

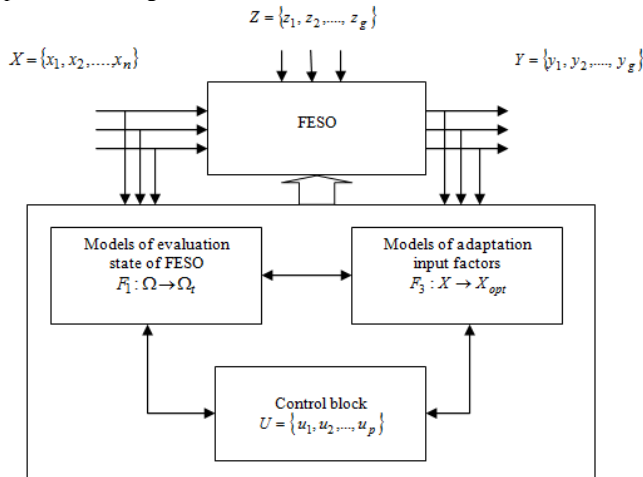

Fig.1: Structural diagram of the FESO model

### 3. Classification of actual NFN states

Designing a mathematical model of the internal structure of indicators of the FESO state on the basis of input data of the input set of factors reduces to mapping the space of factors to the state space with a given reliability and accuracy:

$$F: X \rightarrow Y_{opt}, X \subset \mathfrak{R}^m, Y_{opt} \subset \mathfrak{R}, \quad (4)$$

where  $X$  is the vector of signs of the FESO state;  $Y_{opt}$  is the output value of the FESO state class.

Array of signs of FESO  $X^n = \{x_1, x_2, \dots, x_n\} \subset X$  together with the corresponding array of state classes and FESO makes it possible to implement the well-known pattern recognition rule [6]:

$$\varpi_g \in \Omega_k, \text{ if } L(\varpi\{\varpi_g\}) = \sup_i L(\varpi\{\varpi_i\}), L(\varpi\{\varpi_g\}) \rightarrow \varpi_g \in \Omega_k, \quad (5)$$

where  $\vec{X} = (x_1, \dots, x_n) \in X$ ;  $L(\varpi\{\varpi_g\})$  is the allocation rule of FESO  $\varpi_g$  to the corresponding class;  $\{\varpi\}$  is a set of FESO states  $(p, g)$  in feature space  $(k, l)$  with all their possible combinations  $(\varpi_{pk}, \varpi_{gl})$ .

Adaptation of input factors to target states. If the actual state of the FESO does not correspond to the target state, then it is necessary to find the corresponding set of input factors, i.e. solve the inverse problem of recognition: for a given class of FESO, one should find a set of characteristics (factors) that are adequate to this state. Formally, the discrepancy between the actual and target states in the neural network format is formalized in the form [7]:

$$\frac{1}{mn} \sum_{j=l=1}^n \sum_{m} (y_{ij} - d_{ij})^2 \Rightarrow \min(\mathfrak{R} \leq \mathfrak{R}_0), \quad (6)$$

where  $y_{ij}$  is the vector of indicators of output states;  $d_{ij}$  is the result of network training on  $j$  which is output, at  $i$ -m example of training sample;  $j = 1, n$  is the network output number;  $i = 1, m$  is the example number;  $m, n$  are the dimension of the array of examples and the number of output elements of the network;  $\mathfrak{R}_0$  is the permissible constraints on the condition of the problem. Solving of the task of minimizing the objective function (4) in the statement of the problem is iteratively performed in the process of

learning the network using the algorithm for back propagation of the error [7] with respect to the input factors of the FESO under investigation:

modification of the synaptic space by adjusting the weight coefficients in the direction of the antigraded discrepancy

$$w(t+1) = w(t) - \mu \left( \frac{\partial E}{\partial w} \right), \quad (7)$$

where  $\mu$  is the learning factor;  $E$  is the residual function (error).

If  $Y$  represents the current (current) state of the FESO, and  $Y^*$  is the network response, then the formal adaptation process is represented by the well-known algorithm [7] and we present a network error like:

$$E^* = \frac{1}{2} (e^*)^2 = \frac{1}{2} (Y - Y^*)^2 \text{ then}$$

$$Y^* = f_{out}^e \left\{ \sum_{i=1}^{N_2} w_i^{e_2} f^{e_2} \left[ \sum_{j=1}^{N_1} w_{ij}^{e_1} f^{e_1} (y_j^{e_1}) - b_i^{e_2} \right] - b_{out}^e \right\} \quad (8)$$

where  $f_{out}^e(\cdot), f^{e_2}(\cdot), f^{e_1}(\cdot)$  are activation functions of neurons of the 2nd and 1st layers;  $w_i^{e_2}, w_{ij}^{e_1}$  are weight coefficients of neurons on the sections between the neurons of the 2-3rd and 1-2th layers;  $b_{out}^e, b_i^{e_2}$  are the thresholds of the output neurons and the hidden layer.

For neurons, a linear signal function is used at the input, and a sigmoid layer for the hidden layer. The threshold at the output is usually zero.

Further, the derivative of the discrepancy function is estimated and actions are performed by a known technique [6].

Instrumentally, the task of adapting network inputs to its target state is solved in the paradigm of existing gradient methods of adapting the input vector to a given function at the output [7]. In this case, the method of back propagation of an error is consistently applied in two stages:

1. to adjusting the parameters of a neural network when its synaptic space is modified;
2. to adjust the input vector through the error gradient of the input signals of the network.

The input factors of the FESO, corresponding to its required class, were fed to the input of the trained network. Taking into account the given response and the response given by the network, the error gradient of the input function of the network was calculated using the known technology of the loaded dual networks method [7].

The task of teaching the NA has two phases. The first one represents the assimilation of the initial functions of NEs and NDs, which approximate the dynamics of the managed state of the FESO, and the second one is carried in support of adaptive control.

The structure of the interaction of factors, errors and control actions is explained by the scheme:

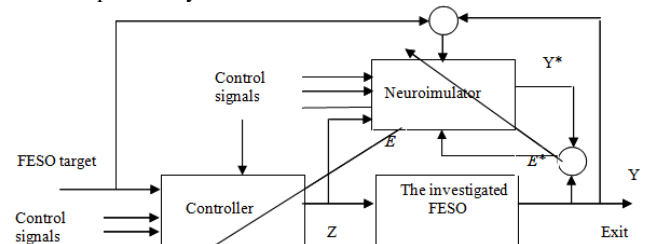

Fig.2: Block diagram of input adaptation

After achieving the necessary accuracy of the autonomous reaction of the NF, additional training is provided for both neural networks on the examples of control of the FESO at its various values.

The second phase of learning neural networks of the neural control system takes place in the operating mode of the controlled object, which requires a strict schedule for performing control operations and adjusting the network parameters. Each new implementation completes the training sample for operational learning.

Algorithm for realizing the process of adaptation of input factors to states (FESO)

Option 1

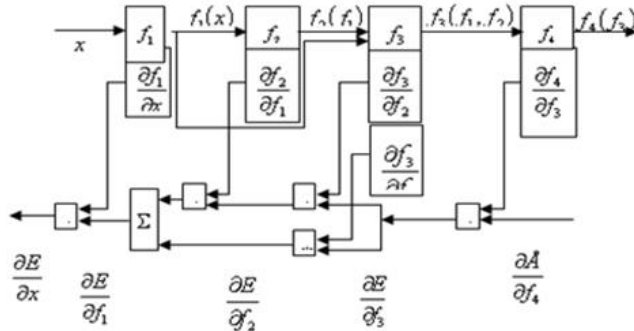

Option 2

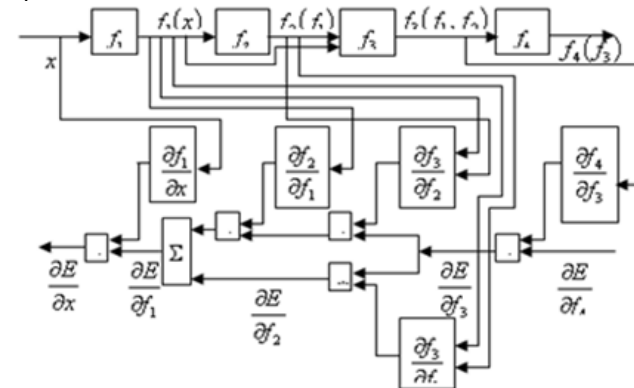

Options for calculating the gradient elements of the residual function are presented above.

Both variants realize the correction of the starting values of the input vector of the network by an algorithm similar to the algorithm of learning the neural network, until the moment of obtaining the required state at its output. Methods based on the back propagation algorithm are used to calculate the partial derivatives of the deviation function of the network output from the required state from of the values of the input signals [3,6]. This makes it possible to determine the magnitude and direction of the maximum changes in the discrepancy between the two FESO states and to correct the input signals along the anti- gradient direction. This provides algorithmic adaptation of the values of the input vector to the target state of the object under study. Gradient descent will lead to one of the possible solutions of the inverse problem, which is the initial input array for instrumental support of DM decisions. Implementation of this approach is carried out using the construction of a neural network model and its training by the AN method Gorban [8]. The method allows to calculate the derivatives of the residual function of the current and required FESO states for each element of the input factor vector and store them. In inverse operation, these previously calculated derivatives are used to calculate the gradients over the input signals of the network.

In this case, after completing the network training, the set of synaptic coefficients becomes unchanged, and the set of indicators of the current state becomes what it was before the training began. At this stage, the minimization of the discrepancy with respect to the integral index is repeated by the search for the antigradient, but the vector of input factors becomes variable. Since the object has a target vector of indicators  $Y_c^k$ , then the residual function takes the form:

$$E(X) = \frac{1}{2} \sum_{i=1}^M (y_i(x) - y_{iz})^2 \tag{9}$$

Modification of the space of input factors is carried out on the basis of the gradient method:

$$X^{t+1} = X^t - \eta_1 \cdot \text{grad}E(X^t) \tag{10}$$

The components of the gradient of the residual function are calculated according to the procedure given in [8].

In our case, the efficiency index is a function of several input factors.

In this case, each set of factors  $x_1 \in D_1, x_2 \in D_2, \dots, x_n \in D_n$  a number is put in correspondence (indicator of the FESO state)  $y = (x_1, x_2, \dots, x_n)$ , which characterizes this or that side of the investigated object (profit, profitability).

This characteristic formally defines the function of n variables at the points corresponding to the values of the indicators in the region of admissible values of the input factors of the state of the object (FESO):

$$y = f(x_1, x_2, \dots, x_n) \tag{11}$$

Let us imagine the function  $f(x_1, x_2, \dots, x_n)$  is differentiable at the point  $A(x_1, x_2, \dots, x_n)$ . The gradient of the function  $\nabla f(x_1, x_2, \dots, x_n)$  is a vector whose coordinates are equal to the partial derivatives with respect to the corresponding coordinate

$$\nabla f(x_1, x_2, \dots, x_n) = \begin{pmatrix} \frac{\partial f}{\partial x_1}(x_1, x_2, \dots, x_n) \\ \frac{\partial f}{\partial x_2}(x_1, x_2, \dots, x_n) \\ \dots \dots \dots \\ \frac{\partial f}{\partial x_n}(x_1, x_2, \dots, x_n) \end{pmatrix} \tag{12}$$

Geometrically, the resulting direction of the gradient of the function coincides with the direction of the steepest increase in the efficiency index given by this function, and its modulus is equal to the partial derivative of this function in the given direction. Therefore, it is necessary to automate the process of determining the elements of the gradient vector by constructing an algorithm and selecting the software tool for its implementation. This problem is solved by applying the technology of the universal loaded method of measuring the elements of the gradient in the backward propagation of the error [8]. At the same time, the weight coefficients of the ensemble of neural networks assume fixed values for the time of adapting the input factors to the corresponding states (classes) of the object under study.

The generalized algorithm for adapting the inputs is expressed by the formula:

$$X_{k+1} = X_k + \Delta_k P_k, \tag{13}$$

where the vector  $p_k$  are sets the direction of motion, a  $\Delta_k$  is a step size at the k-th iteration.

The formula for calculating the vector is the following:

$$P_k = g_k + \sum_{i=1}^k B_k \cdot g_{i-1} \tag{14}$$

where the vector  $p_k$  are sets the direction of motion;  $g_k$  is the direction of the antigradient at the k-th iteration;  $B_k$  is the coefficient determining the weight of the i-th gradient; k is the sequence number of the current iteration.

Thus, the proposed algorithm is the solution of the last stage of the process of changing the input factors when they are adapted to the state of the FESO of a given class.

The general algorithm for this process is:

1. Start.
2. Selecting the starting point with coordinates  $(x_{10}, x_{20}, \dots, x_{n0})$
3. Checking the stopping criterion (the number of iterations, the mean square error of training, etc.).
4. Computing the antigrade at the current point  $g_k$ .
5. Memorizing the current direction in the directions file.
6. Calculating of the direction vector  $p_k$  by the formula 14.
7. Moving in the space of factors to a new point corresponding to the computed vector  $p_k$ .
8. Returning to step 2 and checking the stopping criteria. If the result is positive, the algorithm ends, and if the result is negative, one should go to step 3.
9. Stop. The point found corresponds to the minimum of the residual function.

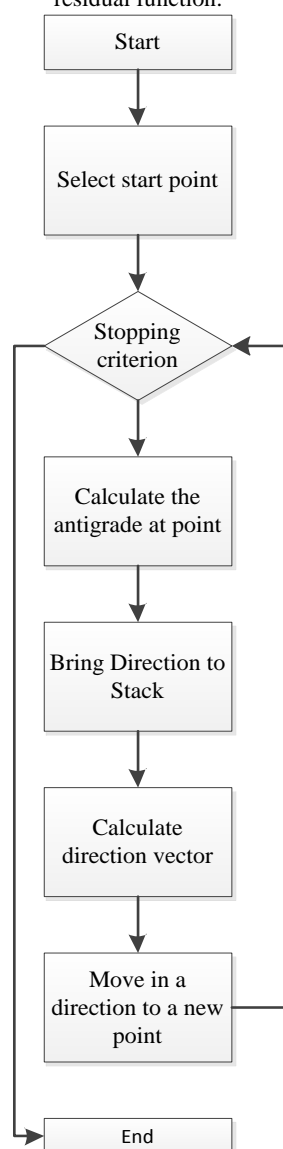

Fig.3: The algorithm for adapting the inputs of the CCTS

Thus, mathematical, algorithmic and instrumental procedures for solving two relatively independent procedures are presented:

- construction of an adequate model of the current state of the studied state of the FESO;
- finding the vector of input factors corresponding to the target state within the limits of permissible deviations.

The next stage is the description of the FESO classes in the language of their informative features.

Generalizing indicators of financial and economic efficiency of production are profit and profitability. Profit in market conditions is the main goal of entrepreneurship and the criterion of production efficiency. Profit is a net income, expressed in monetary terms, representing the difference between aggregate income and total costs. The enterprise receives profit if the sales proceeds exceed the cost of goods sold (works, services). Profitability characterizes the effectiveness of using the means of production and labor. It is defined as the ratio of the profit received by the enterprise to the amount of fixed and circulating funds. Profitability management (planning, justification and analysis-control) are at the center of the economic activity of enterprises operating on the market. In our task, profit and profitability are the markers of the output state of the FESO. As defined factors that affect profit will be income and expenses.

Revenues are divided into:

- income from ordinary activities;
- operational;
- non-sales;
- extraordinary.

Revenues from ordinary activities are revenues from the sale of products and goods, income associated with the performance of work, the provision of services.

Operating revenues include:

- payment for temporary use (temporary possession and use) of the assets of the enterprise;
- payment for rights to patents for inventions, industrial designs and other types of intellectual property;
- income associated with participation in the authorized capitals of other enterprises (including interest and other income from securities);
- profit received by the enterprise as a result of joint activities (under a simple partnership agreement);
- proceeds from the sale of fixed assets and other assets other than cash (except for foreign currency), products, goods;
- interest received for the provision of funds for use of the enterprise, as well as interest for the use of the bank funds held in the account of the enterprise in this bank.

Non-operating income is:

- fines, penalties, penalties for violation of the terms of contracts;
- assets received free of charge, including under a gift contract;
- receipts for damages caused to the enterprise;
- profit of previous years, revealed in the reporting year;
- amounts of creditor and depositor debts for which the limitation period has expired;
- exchange differences;
- the amount of revaluation of assets (excluding non-current assets);
- other non-operating income.

Extraordinary income is defined as income arising as a result of extraordinary circumstances of economic activity (natural disaster, fire, accident, nationalization, etc.): insurance compensation, the value of material assets remaining from the write-off of assets unsuitable for restoration and further use, etc. Depending on the directions of the enterprise, the main (usual), investment and financial, the revenues are the following:

1. Income from the main activity is the proceeds from the sale of products (works performed, services rendered).
2. Income from investment activities, which is the financial result from the sale of non-current assets, sale of securities.
3. Income from financial activities includes the result of placement among investors of bonds and shares of the enterprise. It is obvi-

ous that formally revenue is a vector with the above elements.

Expenses are similar. All the company's cash costs are grouped according to three characteristics:

- expenses related to the extraction of profits;
- expenses not related to the extraction of profit;
- compulsory expenses. Expenses related to the extraction of profit include:
- costs for the production and sale of products (works, services);
- investment.

The costs of production and sales of products (works, services) are the costs associated with the creation of goods (products, works, services), as a result of the sale of which the enterprise will receive a financial result in the form of profit or loss.

Investments are capital investments in order to expand the volume of their own production, as well as the extraction of income in the financial and stock markets.

Expenditures not related to the extraction of profit are consumption expenditure, social support of employees, charity and other humanitarian purposes. Such expenses support the public reputation of the enterprise, contribute to the creation of a favorable social climate in the team and ultimately contribute to higher productivity and quality of work.

Compulsory expenses are taxes and tax payments, deductions for social insurance, expenses for compulsory personal and property insurance, creation of mandatory reserves, economic sanctions.

1) According to the accounting principle, expenses are classified into:

- expenses for ordinary activities;
- operational expenses;
- non-sales;
- extraordinary expenses.

Expenses for ordinary activities are the costs associated with the manufacture and sale of products, the acquisition and sale of goods, as well as costs, the implementation of which is associated with the performance of work and the provision of services. This includes management and commercial expenses.

Operating costs include these following:

- costs associated with the provision for the payment for temporary use (temporary possession and use) of the assets of the enterprise;
- costs related to the granting for payment of rights to patents for inventions, industrial designs and other types of intellectual property;
- to participate in the authorized capitals of other enterprises;
- costs related to the sale, retirement and other write-off of fixed assets and other assets, other than cash (except for foreign currency), goods, products;
- interest paid by the enterprise for the provision of cash (loans, loans) for use;
- to pay for services rendered by credit institutions;
- other operating expenses.

Non-operating expenses are:

- fines, penalties, penalties for violation of the terms of contracts;
- compensation for damages caused by the enterprise;
- losses of previous years recognized in the reporting year;
- the amount of accounts receivable for which the limitation period has expired, other debts which are not possible to collect;
- exchange differences;
- the amount of asset impairment (excluding non-current assets);
- other non-operating expenses.

Extraordinary expenses include expenses arising as a result of extraordinary circumstances of economic activity (natural disaster, fire, accident, nationalization of property, etc.).

Based on this classification, the Profit and Loss Statement is prepared.

The costs of the main activity are grouped by the elements:

- material costs;
- labor costs;
- deductions for social needs (social tax);
- depreciation;

- other costs.

The costs of production and sales of products include:

- material costs, i.e. the cost of commodity production, works, services of materials consumed in the process of production;
- labor costs and deductions for social insurance;
- costs associated with the management of the production process;
- the cost of non-current assets (fixed assets, intangible assets) used in the process of production, recoverable in the form of depreciation.

Factors of profitability. The main factors that have a direct impact on the increase in the level of profitability of enterprises include:

1. Growth in the volume of production;
2. Decrease in its cost price;
3. Reduction of the turnover time of fixed productive assets and working capital;
4. Growth in the mass of profit;
5. Better use of funds;
6. Pricing system for equipment, buildings and structures and other carriers of fixed production assets;
7. Establishment and compliance with the norms of stocks of material resources, work in progress and finished products.
8. The next stage is modeling.

To solve the problem, we use the standard package of technical analysis STATISTICA 6.0. We fill in the initial data table (1200 rows of the training sample) and start the program in interactive mode.

Then we launch the STATISTICA Neural Network module. In the start window, we select the type of task: "Classification" and the "Wizard" mode.

We define a function and arguments and the select the number of models to save (for example, 5).

Next, we select the ratio of the types of samples: we conduct training, evaluate the result.

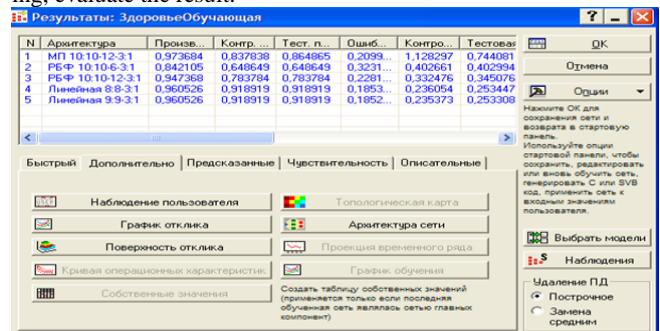

Fig.4: Learning Outcomes

The above makes it possible to come up with the following conclusions:

- the network correctly recognizes classes is adequate;
- reacts with its response to input changes is sensitive;
- by selecting the input you can set the required output is adaptable to the target class.

The efficiency of the declared procedures is proved by a practical example.

When we received 5 networks, then on the "Quick" tab we select the "Network Results" option and find the best one in performance. The best result for the network is number 5, namely: Performance - 0.960526. The test error is (0,253308).

Since each class has its own set of indicators, the procedure for classifying an object is reduced to analyzing the feature space of the current state and comparing the results of the analysis with the descriptions of the selected classes. In the neural network format, the task of recognizing the classes of the current state of the researched subject is solved, for example, using the delta rule [4]. If two classes of states are present the formation of a learning set is simplified. We apply the modeling technology in the environment of neuromemulators according to the technique [4].

As a result of the interactive dialogue, the network model was obtained, its training was carried out, the most productive variant

from the ensemble of models was selected. Models based on radial-base functions on the whole confirm the conclusion about the feasibility of basic functions, but the power of the training sample in the examples given did not allow achieving performance by the condition of the problem.

Lower performance is typical for models with a large number of neurons in the hidden layer, and the user must seek a trade-off between the generalization errors on the test set, training time, and network performance. Therefore, the choice of the final model is carried out by the user based on the features of the subject area of the study, the requirements for the models and the capabilities of the neural area used.

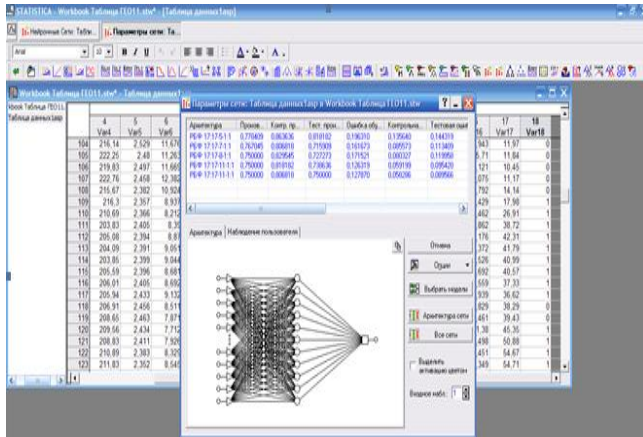

Fig.5: Model profile of the sample fragment for the RBF network

The performance indicators of models depend simultaneously on the power of the training sample and the complexity of the network, its type and architecture. Thus, a theoretical and practical confirmation of the conclusion about the possibility of constructing a model of the FESO, while ensuring the adequacy of the models within the given boundaries, has been obtained.

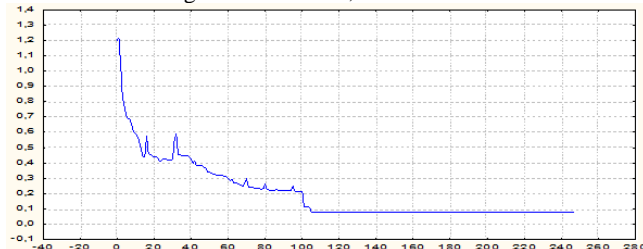

Fig.6: The training schedule on the sample fragment

As can be seen from the graph, the application of the presented technologies to reduce the adaptation time of the neural network models of the base SSTC processes, while maintaining their adequacy within the permissible boundaries, made it possible to obtain a stable convergence of the iterative process of modifying the synaptic space. The number of epochs does not exceed several hundred, which in terms of total time costs corresponds to fractions and tens of seconds.

Thus, the analysis of modeling results in the neural network format generally confirms the theoretical conclusion about the productivity of the constructed FESO models in real time. The results of simulation of gradient descent with estimation of partial derivatives both on the parameters of the network and on the input signals representing the space feature of the current state of the FESO showed stable convergence of the iterative learning process of the network with acceptable quality indicators.

For various modeling conditions, an ensemble of productive neural networks was obtained, which can be used in separate applications based on their preservation in the basic code format.

The next step is to estimate the optimality of the simulation results. We apply the method of estimating the reliability and accuracy of decision making by neural network models of data analysis in invariant domain of FESO [1]. The approach is based on the

idea of using the statistical method of an ideal observer with its adaptation to a neural network format in the environment of standard emulators of artificial neural networks. A substantiation of the adequacy of the statistical decision rule for hypothesis testing and training of a neural network on the basis of the duality principle is presented.

The optimality of the decisions made by neural network models in collective voting schemes and the invariance of the ideal observer criterion to its instrumental implementation have been investigated.

Modern analytical systems make decisions on the management of complex systems, which are a problematic object for modeling system-forming processes because of their characteristics as in our case. As a rule these processes, are difficult to formalize and are weakly amenable to analytical representation, which prevents the identification and formalization of the main factors, the relationships between them and the strength of the influence of individual factors on the final result. Therefore, collective statistical methods [1] are often used in decision making, when the weight of an individual voice (expert or technical tool) can vary over a wide range. However, in a number of subject areas, only information and technical means (autopilots, weapons control systems, energy management in the region, etc.) have to be relied on.

In this case, the problem of modeling decision making by technical means in the automatic mode is actual. Classical ACS with feedback in FESO is ineffective, for the reasons noted above, therefore it is advisable to use intelligent technologies in the format of artificial neural networks (ANN), as we did. In our case, there is a significant array of a priori and current data, which is an objective basis for the productive use of intelligent technologies for transforming the database into a knowledge base sufficient for making productive decisions.

Then the information-analytical approach based on precedents that contain information about the laws of factors and states, their mutual influence, the strength and direction of influence, for decision-making becomes extremely important. At the same time, it is necessary to decompose system-forming processes to a level sufficient to describe the language of technical means, to find a formal display in the "input-output" format, to implement them in the software language, to compose the obtained algorithms and interpret the results.

In our case, decisions are made on the classification and management of the input set.

The problem of classification of the investigated object (FESO) is solved by several models and each of them uses the rule of the ideal observer, i.e. minimizes the general classification error.

When determining the classification error, the result of an erroneous decision is an event where an object belonging to a class is classified as an object of class. In our case, when studying FESO, the same signs of different classes take their values on coincident intervals, so mistakes are unavoidable. All that can be done in this situation is to minimize errors. We will assume that the alphabet of classes is described, that is, for each object a set of attributes  $\{x_j\}_j$  and the object is completely determined by them. Analysis

of the description of the state of the object gives the current information, on the basis of which the information is determined a posteriori. The nature of the current and a posteriori information is determined by what decision rule is implemented in the classifier. Since the ultimate goal is to maximize the reliability of decisions, it is advisable to apply the statistical rule of an ideal observer and confine oneself to them. Under these conditions, the definition of current information is reduced to calculating the likelihood function

$P\left(\frac{x_j}{A_i}\right)$ ,  $i = 1, 2, \dots, M$ , and a posteriori to the calculation of a posteriori probabilities [4].

$$h_{ij} = P\left(\frac{A}{x_{ji}}\right) = \frac{P(A_i)P\left(\frac{x_j}{A_i}\right)}{\sum_{i=1}^M P(A_i)P\left(\frac{x_j}{A_i}\right)}, \quad i=1,2,\dots,M, \quad (15)$$

where  $\sum_{i=1}^M P(A_i)P\left(\frac{x_j}{A_i}\right)$  is a generalized probability distribution of

the values of the characteristics of the classes (states) of the investigated object (FESO).

Posteriori probabilities are determined for each state (class) of the object under study and, based on the chosen a posteriori distribution of characteristics, a decision is taken on the class of the state of the object under study based on the chosen criterion of the ideal observer.

The next step in the classification is to decide whether this state belongs to the class that corresponds to the maximum a posteriori probability or probability of the hypothesis. In conclusion, there is a decision error on the simple relation^

$$\lambda_{ij} = 1 - h_{ij}, \quad (16)$$

where  $\lambda_{ij}$  is the probability of an error as a decision of assignment  $j$ -th the state of the object to  $i$ -th the class,  $i=1,2,\dots,M$ .

The conclusion about the effectiveness of such an approach is confirmed by the internal generality of the decision making procedures for the statistical rule of the ideal observer and the modification of the synaptic space of the artificial neural network. Indeed,

the likelihood function  $P\left(\frac{x_j}{A_i}\right)$  from expression (15), is a mathematical mechanism for mapping the current set of characteristics

$(x_j)$  with one ( $i$ -m) state of the object of investigation. In a neural network, one epoch of learning is characterized by the submission to the network of the entire set of characteristics and ends with the change and fixation of a full array of synaptic coefficients.

The procedure for learning the neural network is based on the search for all possible combinations of the synapse weights, for example, according to the algorithm for back propagation of the error [4] in the form:

$$w_{hq}^{(n)}(t) = w_{hq}^{(n)}(t-1) + \Delta w_{hq}^{(n)}(t), \quad (17)$$

where  $w_{hq}(t-1) = w_{hg}(t) + \alpha \cdot \frac{\partial E(k)}{\partial w_{hq}(t)}$ ;  $w$  is the array of synaptic

coefficients;  $q$  - neuron output number in the  $n$ th layer;  $h$  - neuron input number in the  $n$ th layer;  $n$  is the number of the network layer. Consequently, the associative memory of the network with each subsequent epoch reflects the integrative impact of the entire set of input samples. In terms of its information essence, it is a neural network analog of the generalized probability distribution of the values of the characteristics of the classes (states)

$\sum_{i=1}^M P(A_i)P\left(\frac{x_j}{A_i}\right)$ , where  $i=1,2,\dots,M$  from expression (15).

Therefore, it is logical to assume that this is a kind of analogue of the likelihood function (15) in the neural network format.

The second step in the implementation of the ideal observer rule only strengthens the confidence in the validity of this assumption. Indeed, the further process of realizing the statistical rule of an ideal observer consists in looking through all combinations of the attributes of classes without exception and comparing them with the generalized probability distribution of the values of the object state characteristics.

For each set, the value of a posteriori probability is calculated. In

the neural network, there is also a procedure for enumerating the entire set of realizations of characteristics and comparing their effect on the generalized objective function by fixing the learning error on the control set.

At the last step of the decision on the statistical rule (13), the maximum value, which is substituted into (14), is selected from the whole array of a posteriori probabilities found, minimizing the resulting error. And at this stage the neural network works by a similar analogy to the statistical decision rule. The difference is that if the statistical algorithm involves the search for the maximum of a posteriori probability in the form (13), then the neural network in the process of learning with the teacher finding the minimum of the error of the objective function in the format of a quadratic form of the form:

$$E(w) = \sum_{k=1}^P (d^k - y^k)^2, \quad (18)$$

where  $P$  is the dimension of the input parameter vector;  $d^k$  is the reference (desired) network output for the  $k$ -th parameter;  $y^k$  is real network output for the  $k$ -th parameter. Taking into account expression (14), there is every reason to speak about the adequacy of these procedures for finding the optimal solution.

Indeed, maximizing the probability of a correct solution in optimization problems is equivalent to minimizing the probability of an erroneous solution. The difference is determined only by the specific features of the subject area, technical and economic opportunities for the formation of a space of informative features and the choice of decisive rules. The last and most important condition for the commonality of the statistical and neural network approaches in optimizing the reliability of the decisions made is that in either case the necessary data for decision-making are extracted from a set of precedents of large dimension. This condition allows us to generate consistent and sufficient statistics for the ideal observer criterion and a representative training sample for modifying the synaptic space of the neural network.

Therefore, the base for extracting knowledge about the states of the object under study both in the statistical and neural network formats is the same - an array of precedents, which is an objective condition for the legitimacy of the conclusions drawn. In this case, the criterion of an ideal observer is realized and described analytically on known models of distributions of features and classes. The internal nature of neural network training, unfortunately, for today does not have an analytical interpretation.

Thus, these conclusions extend to each model from our ensemble of trained networks, the productivity of each of which (probability of recognition) is characterized by an individual profile. Practical implementation of the neural network version of the rule of an ideal observer for checking statistical hypotheses can be demonstrated on the model of an artificial neural network in the environment of standard neural emulators Statistika Neural Network. Proceeding from the noted features of building networks and studied subject areas, each profile will be considered as an independent voice of a neural network expert and each element of the profile - as individual features of such an expert.

The algorithm for back propagation of the error and its modification allows only minimizing the difference between the current and target state by the selection of weight coefficients.

Therefore, for practical problems of classification and management of FESO, finding the minimum error value in the process of modifying the synaptic weights on the training, control and test sets is necessary and sufficient condition for ensuring the reliability of solving the classification and adaptation problems of the system under study.

Thus, the analysis allows us to see the essential generality and the unified logic of error minimization using the statistical criterion of the ideal observer in the space of hypotheses of belonging to classes and training the neural network in the space of synaptic



weighting coefficients. This conclusion is key, since the criterion of an ideal observer allows finding optimal solutions from all possible. If a solution with the same quality can be provided by a neural network, then the decision-making of an ensemble of models based on packets of standard neuromemulators essentially allows obtaining well-founded solutions with predictable reliability. This is especially important for tasks such as ours, where, due to circumstances (time limit, high degree of uncertainty, multifactority, active resistance, etc.), neural networks can be the only productive technical tool to support decision making.

Adequacy of neural network models established by the amount of productivity, errors in training, control and test sets when training on a representative sample of examples, allows us to assert the consistency of decisions made by the results of modeling [1,7]. In practice, this makes it possible to confirm the possibility of finding and maintaining the optimal value of the financial and economic state of the enterprise under study at which the optimum level of profit and profitability will be achieved with allowable variations by using a set of input factors, which is the purpose of our simulation.

#### 4. Conclusions

1. In order to automate the determination of the values of the factors that bring the actual state of the FESO to the target one, it is necessary to find the functional dependence of its states on the values of the factors. This problem has been solved using the technology of neural control and realized by models of multilayer perceptrons as the inverse problem of recognition.
2. The calculation of partial derivatives with respect to the input factors of the output function of the residual of the current and required states of the NNF and the generalized gradient estimation are based on the known properties of neural network circuits functioning in the "emulator-controller" bundle. This allowed us to automate the process of determining the gradient elements when implementing the traditional method of back propagation of the error.
3. Practical significance of the research results is the creation of software tools for transition to automatic systems for adapting the space of input attributes to the space of required classes in the management of the financial and economic state of the enterprise.
4. The developed technology, methodical, algorithmic and software tools allow automating the processes of classification of FESO states, adaptation of input factors to the target state of the object.
5. Modeling and interpretation of results on the platform of neuromuscles is an effective tool for automating decision-making in real-time management for the enterprise economy.
6. Functionally, the program of trained models can be implemented as a program unit for analyzing data and making decisions in the format of two basic subsystems for classifying the states of the object of research and adapting input factors to target states that interact with each other on the basis of interrelated data analysis tasks.
7. Providing functions of the developed information systems are represented by solving the tasks of gathering information resources, storing, processing, updating them and are implemented by their own programs or on the basis of existing platforms for developing and implementing expert applications and processing user requests.

Automation of basic FESO processes, performed on the basis of practical implementation of artificial intelligence capabilities in the neural network format, allows increasing the enterprise's competitiveness and reduces production costs.

#### References

- [1] Aleshin S.P., Neural network basis of decision support in the space of factors and states of high dimension, *SkyTech* (2013) – P.208.
- [2] S.P. Aleshin & E.A. Borodin (2013), Neural network controlling of the dynamics of processes as a space of states of high dimension, *Bulletin RGUPS* 4, 35 – 42.
- [3] Khaikin, S., *Neural networks: Full course. 2nd edition*, Williams (2006), P. 1104.
- [4] Buslenko N.P., *Modeling of complex systems. 2nd ed.*, Science (1978), P. 400.
- [5] Galushkin A.I. *Neurocomputers and their application at the turn of the millennia in China*, Science (2004), pp. 367 – 464.
- [6] S.P. Aleshin & E.A. Borodin Neural network class recognition in real time, *Engineering Bulletin of the Don*, No.1 (2013), available online: <http://www.ivdon.ru/magazine/archive/n1y2013/149>
- [7] A.L. Lyakhov, S.P. Aleshin & E.A. Borodina (2012), Neural network modification of the current feature space to the target set of classes No. 4 (29) *News of Donbas State Machinery and Academy*, pp.99 –104.
- [8] Gorban A.N. & Rossiev D.A. *Neural networks on a personal computer*, Novosibirsk: Nauka, (1996), P. 276 p.
- [9] D. Jarratano & G. Riley. *Expert systems. Principles of programming development*, Ed. Williams (2006) P. 2104.
- [10] Morozov A.A., Klimenko V.P., Lyakhov A.L. & Aleshin S.P. (2010), The state and prospects of neural network modeling of DSS in complex socio-technical systems *Mathematical Machines and Systems* 1.,127 – 149.
- [11] A.L. Lyakhov & S.P. Aleshin (2010), Complex socio-technical system as an object of control of an artificial neural network, *News of the Academy of Ukraine* 1, 93 – 97.
- [12] A.L. Lyakhov & S.P. Aleshin (2009), Intelligent data analysis in applied economic problems, *Science Bulletin of Poltava National Technical University. Economics and Regions* 4 (23), 140 - 147.
- [13] S.P. Aleshin & E.A. Borodin (2013), Neural network optimization of the fiscal and tax burden as an element of digitization of the regional economy, *Control systems, navigation and communication*, No.3(49), (2018), pp. 88 – 93, <https://doi.org/10.26906/SUNZ.2018.3>
- [14] Lvovich I.Ya., Chervonyi IF, Gafiiak A.M. and other *Perspective achievements of modern scholars*, Kuprienko SV, (2017), P.-219, <https://doi.org/10.21893/978-617-7414-13-0-0>