

UDC 624.012.45.044

*V.P. Mitrofanov, PhD, Head of the Center for ADMCS
Center for Advanced Design Methods of Concrete Structures, Poltava, Ukraine
N.M. Pinchuk, PhD, senior lecturer
P.B. Mitrofanov, PhD, senior lecturer
Poltava National Technical Yuri Kondratyuk University, Ukraine*

ABOUT NECESSITY OF THE GENERAL THEORY OF REINFORCED CONCRETE AND ITS ROLE IN THE ADM MODEL CODE

The system Analysis of the Eurocode 2 and fib Model Code 2010 show their common radical demerit: the absence or incompleteness of links between partial and general designs (empirical usually), that leads to the derivation impossibility of reinforced concrete (RC) elements (RCE) design with partial stress-strain state (SSS) from RCE designs with more general SSS. The shown demerit in accordance with the system Approach means the necessity of more high development level of the noted code designs what is caused by the empirical designs dominance that is by absence of the enough General Theory of RC (GTRC). It is stated the essence of the GTRC taken as a principle of the more perfect ADM Model Code, being worked out by the Center for Advanced Design Methods of Concrete Structures (Poltava, Ukraine, E-mail: vpm.admcs@mail.ru).

Keywords: reinforced concrete structures, designs, disadvantages, links, General Theory of RC.

УДК 624.012.45.044

*В.П. Митрофанов, к.т.н., керівник центру ПМРЗБК
Центр передових методів розрахунку залізобетонних конструкцій, Полтава, Україна
Н.М. Пінчук, к.т.н., ст. викладач
П.Б. Митрофанов, к.т.н., ст. викладач
Полтавський національний технічний університет імені Юрія Кондратюка, Україна*

ПРО НЕОБХІДНІСТЬ ЗАГАЛЬНОЇ ТЕОРІЇ ЗАЛІЗОБЕТОНУ ТА ЇЇ РОЛІ У МОДЕЛІ НОРМ ADM

Системний аналіз Eurocode 2 та проекту fib Model Code 2010 показує їх спільний корінний недолік: відсутність або неповноту зв'язків між окремими та загальними розрахунками (звичайно емпіричними), що приводить до неможливості виведення розрахунків залізобетонних (ЗБ) елементів (ЗБЕ) з окремим напружено-деформованим станом (НДС) із розрахунків ЗБЕ для більш загального НДС. Згідно із системним підходом відмічений недолік означає необхідність підвищення рівня розвитку вказаних нормативних розрахунків, що обумовлено засиллям емпіричних розрахунків, тобто відсутністю досить загальної теорії залізобетону (ЗТЗБ). Викладено сутність ЗТЗБ, покладену в основу проекту більш досконалих норм проектування ЗБ конструкцій ADM Model Code, які розробляються Центром передових методів розрахунку ЗБК (Полтава, Україна, e-mail: vpm.admcs@mail.ru).

Ключові слова: залізобетонні конструкції, розрахунки, недоліки, зв'язки, загальна теорія залізобетону.

*В.П. Митрофанов, к.т.н., руководитель центра ПМРЖБК
Центр передовых методов расчета железобетонных конструкций, Полтава, Украина
Н.М. Пинчук, к.т.н., ст. преподаватель
П.Б. Митрофанов, к.т.н., ст. преподаватель
Полтавский национальный технический университет имени Юрия Кондратюка*

О НЕОБХОДИМОСТИ ОБЩЕЙ ТЕОРИИ ЖЕЛЕЗОБЕТОНА И ЕЕ РОЛИ В МОДЕЛИ НОРМ ADM

Системный анализ Eurocode 2 и проекта fib Model Code 2010 показывает их общий коренной недостаток: отсутствие или неполнота связей между отдельными и общими расчетами (обычно эмпирическими), что приводит к невозможности вывода расчетов железобетонных (ЖБ) элементов (ЖБЭ) с отдельным напряженно-деформированным состоянием (НДС) из расчетов ЖБЭ для более общего НДС. Согласно системному подходу отмеченный недостаток означает необходимость повышения уровня развития указанных нормативных расчетов, что обусловлено засильем эмпирических расчетов, то есть отсутствием достаточно общей теории железобетона (ОТЖБ). Изложена сущность ОТЖБ, положенную в основу проекта более совершенных норм проектирования ЖБ конструкций ADM Model Code, которые разрабатываются Центром передовых методов расчета ЖБК (Полтава, Украина, e-mail: vpm.admcs@mail.ru).

***Ключевые слова:** железобетонные конструкции, расчеты, недостатки, связи, общая теория железобетона.*

Problem setting. There is urgent necessity of impartial estimation of the quality level of the Eurocode 2 [1], improved fib Model Code 2010 [2] and other alternative offers. As the above documents are man-made socio-technical systems the system approach is most suitable for the noted aim. According to the System Analysis [3] any system development level is evaluated by its system signs: elements composition, links between elements, organization, structure, integral qualities.

The present paper is limited by the analysis of the mentioned above codes only part which concerns the designs of the RCE and RC structures (RCS): their SSS, deforming and destruction processes, these processes modelling, designs algorithms and their realization.

Considering the totality of code designs as system and determining its system properties it is lightly revealed the elements composition – various designs on the limit states. But determination of the second system property – links between elements (designs) – at once shows the absence or incompleteness these links that leads to the derivation impossibility of designs for the RCE with partial SSS from designs (empirical usually) with more general SSS. For example, the cross section strength design under action one moment M must be derived as partial case of more general case of SSS under forces M and Q joint action. Nevertheless in codes designs of all world countries the link between

mentioned designs is absent because the RCE strength design on action of the shear force Q (jointly with M) is based on the empirical relationship from which the known strength design of cross section does not follow with $Q=0$, although this design must be obtained if the RCE failure model under joint action of forces Q and M would be enough perfect.

The elements design cases in which the forces M , Q , N are combined in various way with the torsional moment T are still less connected. For code designs of elements under two- and three-axial SSS (as rule empirical) the absence of common design conceptual basis is especially visible. These designs are different cases of shear, crushing and splitting, punching shear, pressing out of concrete and mortar, pulling out of reinforcement and others (Fig. 1). That is why the code designs do not form the internal system integrity that in accordance with the system approach means the insufficiently high level of those designs development. The source of the unsatisfactory RCS designs level is the empiricism dominance that is absence of the enough General Theory of RC (GTRC).

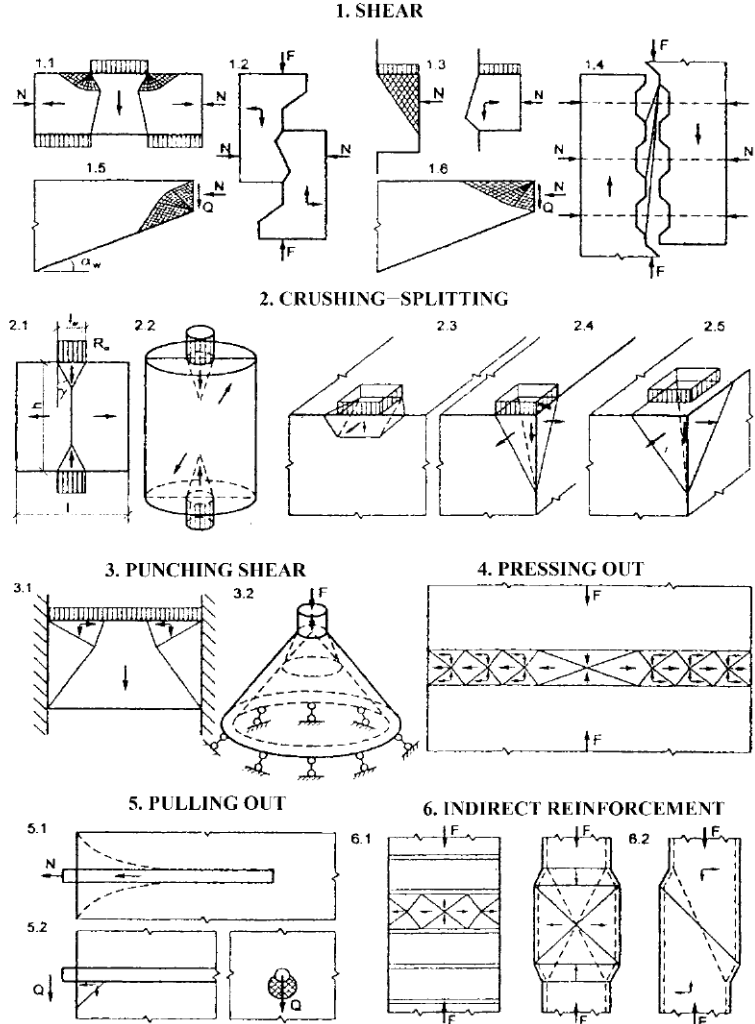

Fig. 1. Elements characteristic groups with failure schemes according to [10 – 12]. The arrows without notation shows the velocity of the corresponding element parts

Thus the codes of all countries include the problem situation caused by the RCS designs development problem. As the RCS designs connections are secured by the GTRC the latter just is the problem-solving system which must generalize, classify and explain the deformation and destruction processes of various RCE on the basis of certain general statements and models.

Researches and publications analysis. A certain continuum model is always put into basis of any concrete or RCE design in which element SSS may be one-, two- and three-axial. Then, meaning the general case of the SSS, it is necessary to base the concrete constitutive model and its stress-strain relationships, that are highly complicated and for GTRC the ones are remained the main difficulty which is not still overcome completely at present in spite of such huge number of suggestions that literature on this question is difficult reviewed. At present it is known the different types of concrete constitutive models (relationships, theories), branching on the certain signs. There are deformation and incremental theories, isotropic and anisotropic models, elastic-plastic models with perfect plasticity or with strengthening [4, 5]. The latter models got more wide application to concrete and RC and especially consequent on its simplicity the model of rigid-perfect-plastic body connected with the Theory of Limit Balance [6]. This model leads to satisfied proximity of theoretical strength to test one not only for bar, slab and shell structures [7 – 9], but for massive three-dimensional elements under two- and three-axial SSS [10 – 12].

Besides the concrete constitutive model the important part of GTRC must be statements that generalize the experimental data of concrete and RC properties to the level of generalized statements and models allowing to reflex the various character of the SSS stages of RCS. Namely *generalized statements and models* form the united conception basis of the GTRC needed for working out of the different designs on various limit states under different RCE SSS.

Paper purpose: to state the essence of the offered GTRC version put into base of the ADM Model Code for RCS projecting that is worked out by the Center for Advanced Design Methods of Concrete Structures (Poltava, Ukraine).

Paper content. The present paper is limited by account of the «first necessity» designs (the GTRC core) which include the designs on strength, crack – resistance and stiffness of RCS under short-time static loading. On the basis of mentioned designs it develops the taking into account of long-time processes, action of different dynamic loads, heat-moisture influences and others. The GTRC core includes: 1) generalized properties of concrete, reinforcement and RC; 2) generalized models of RCE and RCS; problems solving general methods of strength, crack-resistance and rigidity of the RCE and RCS.

Generalized concrete properties

Property C1: depending on sign and value of the mean (hydrostatic) stress (pressure) σ it can be different cases of the concrete deforming behavior and

failure type [11, 12]: brittle, pseudoplastic, perfect plastic (Fig. 2). The pseudoplastic and brittle cases of concrete behavior and failure type have the most practical importance.

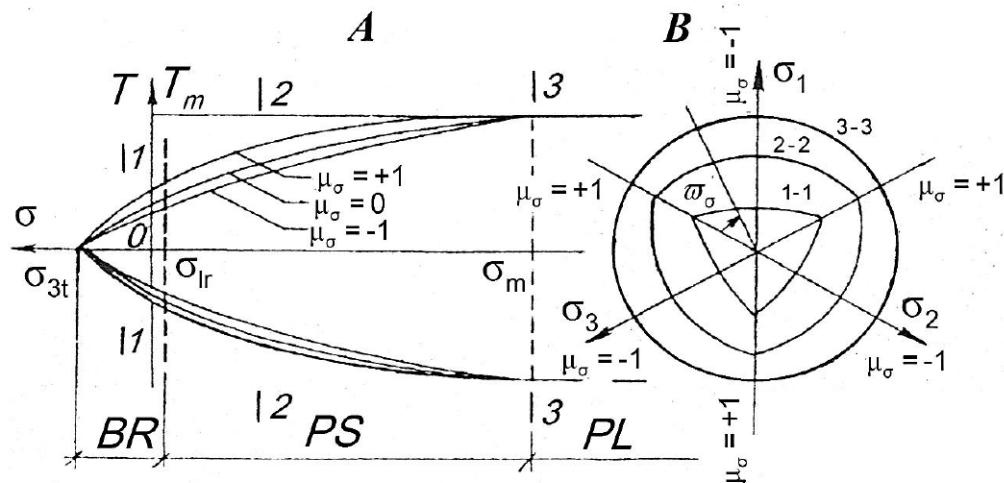

Fig. 2. Meridional (A) and deviatoric (B) sections of the concrete ultimate limit surface, BR, PS, PL – the intervals of brittle, pseudoplastic and plastic failure correspondingly

Property C2: the concrete physical non-linearity and necessity to take into account the descending branch of the relationship «stress σ_{ij} – strain ε_{ij} » under one-, two- and three-axial SSS.

Property C3: Extreme strength criterion (ESC) of concrete and RC elements under non-uniform SSS for the pseudoplastic behavior case. The ESC means the failure state coming in a point when the *strict maximum* of curve «load parameter F – characteristic element strain U_{ch} » is reached

$$F_u = F(U_{ch}) \Big|_{U_{ch}=U_{ch,u}} = \max,$$

where F_u , $U_{ch,u}$ – ultimate load parameter and corresponding characteristic element strain [13, 14].

Reinforcement properties. The GTRC core worked out is limited by the usual steel reinforcement for which unlike recommendations [1, 2] it is used more exact approximations of the tension diagrams $\sigma_s - \varepsilon_s$ by the three-link piece – continuous functions [13].

Generalized properties of RC

Property RC1: the bond between reinforcement and concrete that promotes to their joint deformation. The interaction of reinforcement with concrete is described by the special relationship taking into account the spatial SSS near concrete-reinforcement contact surface.

Property RC2: dependence of the RCE SSS character and failure type on the working reinforcement quantity. This property is well known for partial SSS cases (bending, eccentric compression, torsion et. al.). The Property RC2 was generalized on the case of joint forces M , Q , N action for which the RCE

classification (Fig. 3) was ground depending on quantity both longitudinal A_s and lateral A_{sw} reinforcement, their corresponding resistance use level, RCE behavior character and failure type [15 – 17].

The RCE classification revealed the conditions needed for the *plastic failure on the inclined dangerous crack under shear force Q action* (elements group C on the fig. 3). The RCE classification [15] together with other design statements led to the «Optimization Strength Theory of RCE (OSTRC)» by the inclined sections under joint forces M, Q, N action [15 – 17], which passed the many-sided verifications and showed its practical importance [15 – 21]. The property RC2 is also clear-cut in RCE under the torsional moment T action [22].

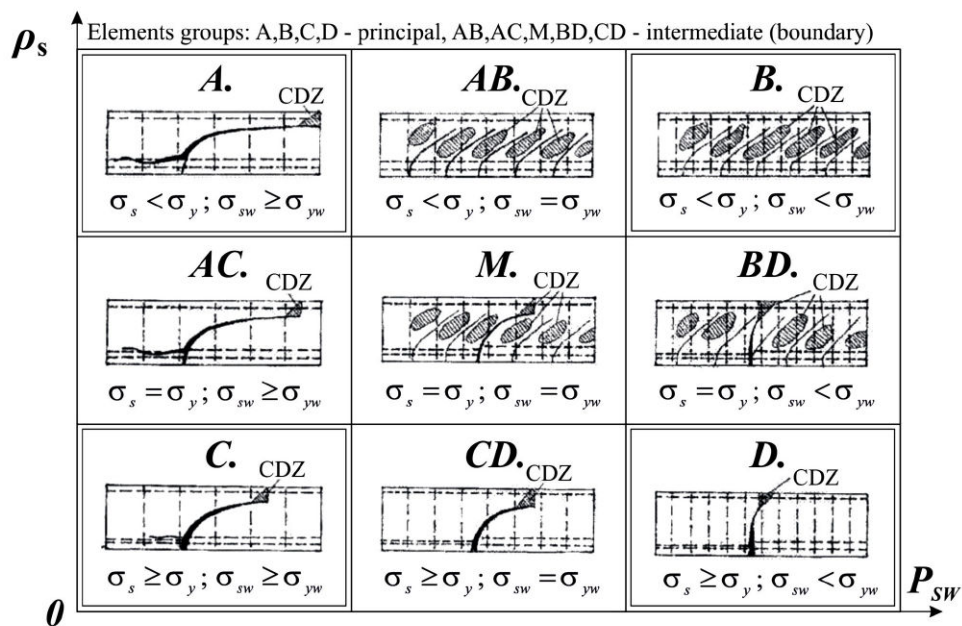

Fig. 3. RC elements classification depending on quantity of longitudinal ρ_{sw} and shear (ρ_{sw}) reinforcement and element destruction type.
CDZ – concrete destruction zone

Property RC3, which allows to make more precise the notion «element of the bar RCS» as part on the length of which the forces M, Q, N, T are sign-constant and both one dangerous inclined and one dangerous normal crack are developed [15 – 17].

Models of RCE and RCS. The Property C1 leads to the important for RCE two cases of concrete deformation and destruction that determine two corresponding types of models – brittle and pseudoplastic – which are able to be basis for various designs of RCE and RCS. In the GTRS offered the two exactness levels of the pseudoplastic model are used: 1) complete pseudoplastic model taking into account the descending $\sigma_c - \varepsilon_c$ branch and ESC which together is effectively realized in strength designs of the RCE cross normal sections with concrete under uniaxial compression [13 – 14]; 2) the approximate pseudoplastic model as model of perfect plastic body used for RCE with two- and three-axial SSS [10 – 12, 21, 24 – 26].

Besides above models it is often needed model as the *combination of brittle and pseudoplastic models*. The necessity of such model is arisen if the RCE has the compressed and tensile with rupture cracks zones.

The Table 1 shows the applicability realms of the above considered models in design on the limit states.

Table 1. Conformity of RCE models types to the main designs groups

RCE model type	RCE DESIGNS GROUPS*					
	on serviceability limit states			on ultimate limit states		
				with failure		with loss stability
	on tensile zone	on compressed zone				
Brittle model	① on formation of normal and inclined cracks	–	–	④ minimum longitudinal and lateral reinforcement	–	–
Pseudoplastic (perfect plastic model)	–	–	–	–	⑤ ultimate load under one-, two- and three-axial SSS	–
Combination of brittle and pseudoplastic models	–	② on opening of normal and inclined cracks	③ on deformation (displacements)	–	–	⑥ critical load of compressed RCE and RCS

Note *: designs on the equilibrium loss of structures as a rigid bodies (overturning, uplift, sliding) are omitted.

Methods of RCE design problems solution. The realization of above models is connected with use the certain methods of practical problems solution which must be accessible for application by the wide society of designers and students. But the Finite Element Method (FEM) does not is such because it demands the complicated, laborious and expensive computer software which is used by the comparatively narrow circle of professionals. Nevertheless there are methods acceptable by their simplicity and accuracy. So for problems connected with the brittle model, the *method of sections of cracks theory* [23] is quite suitable for RCE designs.

The pseudoplastic model design method depends on the its accuracy level used (see above). When the pseudoplastic model is substituted by the approximate model of perfect plastic body one may use design methods from the known arsenal of plasticity theory: the solutions based on the direct variational calculus methods and solutions with interrupted velocity functions which are attractive by their simplicity and sufficient accuracy [10 – 12, 21, 24 – 26].

The Table 2 unites the components of the offered GTRC core and shows their characteristic features.

Conclusions:

1. The System Analysis reveals the insufficiently high development level of designs by the known codes. The shown demerit reason is caused by the empiricism dominance that is absence or insufficient development of the General Theory of RC. The necessity of GTRC was realized in the former USSR by V.M. Bondarenko, V.N. Baikov and V.Y. Bachinski in 1978 – 1979, but its development was proceeded slowly because it not attach importance to the one.

2. It is suggested the GTRC core version, including the generalized properties of concrete, reinforcement and RC, the RCE and RCS generalized models and the models designs general methods.

Table 2. Components of the GTRC offered and design groups in the ADM Model Code for RCS projecting

points order	Components of GTRC and designs groups (№) in ADM Model Code, [references]	Characters of GTRC components and design groups			
		Dimension of considered elements	Elements SSS (forces)	Concrete constitutive model	Model design method
1	⑤ Deformation model with Extreme Strength Criterion on normal sections of RCE, [14, 15]	bar elements, beam slabs	bending (M), eccentrical compression-tension (M, N)	complete pseudoplastic model	non-linear mathematic programming
2	⑤ Optimization Strength Theory of RCE on inclined sections (with torsion), [17, 18]	bar and slab elements	joint action of forces M, Q, N, T	perfect plastic body	non-linear mathematic programming
3	⑤ Elementary mechanics of concrete pseudoplastic ultimate state, [10, 11, 35]	two- and three-dimensional elements	two- and three-axial SSS	perfect plastic body	direct methods of variational calculus on base of variational principles
4	① Designs on formation of normal and inclined cracks, ④ Designs of minimum longitudinal and lateral reinforcement	bar and slab elements	bending (M, Q), eccentrical compression-tension with torsion (M, Q, N, T)	brittle model	method of sections of cracks theory
5	② Designs on opening of normal and inclined cracks ③ Designs on deformation (displacements)	bar and slab elements and structures	bending (M, Q), eccentrical compression-tension with torsion (M, Q, N, T)	combination of brittle and pseudoplastic model	direct methods of variational calculus on base of variational principles
6	⑥ Designs on critical load under stability loss	bar and slab elements and structures	axial (N) and eccentrical compression (M, N)	combination of brittle and pseudoplastic model	direct methods of variational calculus on base of variational principles

Note: The Numbers design groups (№) coincide in the Tables 1 and 2.

3. The recommended models and their design methods are in comparison with the FEM more accessible for use by the wide society of designers and students. The realms of preferable application, on the one hand, the recommended simple models and design methods and, on the second hand, the FEM, exact herewith apart:

for first – the multitude of comparatively simple problems often occurring in the practice for which the failure scheme is enough clear determined (see fig. 1);

for second – the complex many-linked structures in which it is difficult to determine the shape and placing of the destruction field and surface.

4. The sudden failure of concrete and RC element during test does not mean the non-applicability of the perfect plasticity model for this element strength design, if the unstable spreading of rupture macrocrack does not occur.

5. The designers and students society ought to pass the development stage, connected with the more broad use in the RCS designs (including massive three dimensional RCE) the simplest perfect plasticity model in order to master the Continuum Mechanics level needed in future for use of the developing GTRC.

6. The project «*fib* Model Code 2010» makes great progress in direction to the securing structures safety. But the determining models needed for the probabilistic designs are remained on the level close to the level of Eurocode 2.

7. The widened international collaboration for the working out of the more perfect RCS designs is worth-while.

References

1. *Eurocode 2: Design of concrete structures. Part 1: General rules and rules for buildings.* Brussels: CEN, 2002. – 226 p.
2. *Fib Bulletins 55, 56. Model Code 2010. Final draft. vol. 1, vol. 2, 2012.* – 350 p.
3. Перегудов, Ф.И. Введение в системный анализ / Ф.И. Перегудов, Ф.П. Тарасенко. – М.: Высш. шк., 1989. – 367 с.
4. Карпенко, Н.И. Общие модели механики железобетона / Н.И. Карпенко. – М.: Стройиздат, 1996. – 416 с.
5. Nielsen, M.P. *Limit Analysis and Concrete Plasticity. 2-nd ed.* / M.P. Nielsen. – Boca Raton, Florida, USA: CPC Press, 1999. – 908 p.
6. Гвоздев, А.А. Расчет несущей способности конструкций по методу предельного равновесия / А.А. Гвоздев. – М.: Госстройиздат, 1949. – 280 с.
7. Тихий, М. Расчет железобетонных рамных конструкций в пластической стадии / М. Тихий, И. Ракошник, пер. с чешск. – М.: Стройиздат, 1976. – 198 с.
8. Ждахин, Л.П. Расчет железобетонных бункеров по предельным состояниям / Л.П. Ждахин. – М.: Стройиздат, 1970. – 304 с.
9. Овечкин, А.М. Расчет железобетонных осесимметричных конструкций / А.М. Овечкин. – М. Госстройиздат, 1961. – 300 с.
10. Митрофанов, В.П. Вариационный метод в теории идеальной пластичности бетона / В.П. Митрофанов // *Строительная механика и расчёт сооружений.* – 1990. – № 6. – С. 23 – 28.

11. Митрофанов, В.П. Теория идеальной пластичности как элементарная механика псевдопластического предельного состояния бетона: основы, ограничения, практические аспекты, совершенствование / В.П. Митрофанов // Коммунальное хозяйство городов: науч.-техн. сб. – Вып. 72. Серия: Технические науки. – К.: Техника, 2006. – С. 6 – 26.
12. Mitrofanov, V. *The theory of Perfect Plasticity as the Elementary Mechanics of a Pseudo-plastic Ultimate State of Concrete: Bases, Limitations, Practical Aspects, Improving* / V. Mitrofanov // Proc. of the 2nd fib Congress, June 5 – 8, 2006, Naples, Italy. – paper ID7 – 6.
13. Митрофанов, В.П. Практическое применение деформационной модели с экстремальным критерием прочности железобетонных элементов / В.П. Митрофанов // Коммунальное хозяйство городов: науч.-техн. сб. – Вып. 60. Серия: Технические науки. – К.: Техника, 2004. – С. 29 – 48.
14. Mitrofanov, V.P. *Extreme strength criterion and design of RC Elements* / V.P. Mitrofanov // Structural Concrete. Journal of the fib. – 2009. – 10. – № 4. – P. 163 – 172.
15. Митрофанов, В.П. Напряженно-деформированное состояние, прочность и трещинообразование железобетонных элементов при поперечном изгибе: автореф. дис. на соискание науч. степени канд. техн. наук / В.П. Митрофанов. – М.: ВЗИСИ, 1982. – 42 с.
16. Mitrofanov, V.P. *Optimization strength theory of reinforced concrete bar elements and structures with practical aspects of its use* / V.P. Mitrofanov // Bygningsstatistiske Meddelelser. – Copenhagen: Danish Society for Structural Science and Engineering. vol. 71, № 4, Dec. 2000. – P. 73–125.
17. Митрофанов, В.П. Оптимизационная теория прочности железобетонных элементов по наклонным и нормальным сечениям при совместном действии изгибающих моментов, поперечных и продольных сил / В.П. Митрофанов // Будівельні конструкції. Вип. 67. – К.: НДІБК, 2007. – С. 231 – 243.
18. Воскобойник, П.П. Сложное напряженное состояние бетона зоны разрушения и его учет в расчете прочности нормальных сечений железобетонных элементов: автореф. дис. на соискание науч. степени канд. техн. наук / П.П. Воскобойник. – Одесса: ОИСИ, 1985. – 22 с.
19. Котляров, В.А. Прочность железобетонных элементов при совместном действии изгибающих моментов, продольных сжимающих и поперечных сил: автореф. дис. на соискание науч. степени канд. техн. наук / В.А. Котляров. – Полтава: Полтавский инженерно-строительный институт, 1992. – 20 с.
20. Микитенко, С.М. Міцність при згині залізобетонних елементів з повним використанням опору поперечної і високоміцної поздовжньої арматури: автореф. дис. на здобуття наук. ступеня канд. техн. наук / С.М. Микитенко. – Полтава: Полтавський технічний університет, 1995. – 24 с.
21. Mitrofanov, V.P. *Investigation of Destruction Zone Resistance of HSC of Beams under Shear Forces Action* / V.P. Mitrofanov // 5th Int. Symp. on Utilization of HS/HP Concrete, 20 – 24 June 1999, Sandefjord, Norway, proc. vol. 1. – P. 461 – 468.
22. Ernst, G.C. *Ultimate Torsional Properties of Rectangular Reinforced Concrete Beams* / G.C. Ernst // ACI Journal. – 1957. – V. 29. № 4. – P. 341 – 356.
23. Морозов, Е.М. Метод сечений в теории трещин / Е.М. Мороз // Известия вузов. Строительство и архитектура. – 1969. – № 12. – С. 5 – 9.
24. Довженко, О.О. Міцність бетонних та залізобетонних елементів при місцевому

прикладанні стискаючого навантаження: автореф. дис. на здобуття наук. ступеня канд. техн. наук / О.О. Довженко. – Полтава: Полтавський інженерно-будівельний інститут, 1993. – 20 с.

25. Mitrofanov, V. *Strength of Concrete Elements Under Shear Action According to the Theory of Plasticity and Tests* / V.Mitrofanov, V.Pogrebnoy, O.Dovzhenko // *Proc. of the 2nd fib Congress, June 5 – 8, 2006, Naples, Italy.* – paper ID3 – 61.

26. Митрофанов, В.П. Прочность на срез элементов железобетонных рам вблизи шарнирных узловых соединений / В.П. Митрофанов, О.А. Голов // *Збірник наукових праць Полтавського національного технічного університету імені Юрія Кондратюка (галузеве машинобудування, будівництво). Вип. 20.* – Полтава: ПолтНТУ, 2007. – С. 51 – 57.

РЕФЕРАТ

Системний аналіз *Eurocode 2* та проекту *fib Model Code 2010* показує їх спільний корінний недолік: відсутність або неповноту зв'язків між окремими та загальними розрахунками (звичайно емпіричними), що приводить до неможливості виведення розрахунків залізобетонних (ЗБ) елементів (ЗБЕ) з окремим напружено-деформованим станом (НДС) із розрахунків ЗБЕ для більш загального НДС. Згідно з системним підходом відмічений недолік означає необхідність підвищення рівня розвитку вказаних нормативних розрахунків, що обумовлено засиллям емпіричних розрахунків, тобто відсутністю досить загальної теорії залізобетону (ЗТЗБ).

Проект «*fib Model Code 2010*» – це великий прогрес в напрямку забезпечення безпеки споруд. Але основні норми проектування, необхідні для імовірнісних розрахунків конструкцій залишаються на рівні, близькому до рівня *Eurocode 2*.

Розглядаються актуальні проблеми вдосконалення розрахунків залізобетонних конструкцій за граничними станами, котрі містять нові положення (класифікацію залізобетонних елементів і їх моделей, екстремальний критерій міцності, уточнення поняття залізобетонного елемента тощо), що в свою чергу сприяє розвитку необхідної для практики ЗТЗБ і норм проектування залізобетонних конструкцій.

Викладається сутність ЗТЗБ, яка покладена в основу проекту більш досконалих норм проектування ЗБ конструкцій *ADM Model Code*, які розробляються Центром Передових Методів Розрахунку ЗБК (Полтава, Україна, e-mail: vpm.admcs@mail.ru).

Надійшла до редакції 07.10.2013
© V.P. Mitrofanov, N.M. Pinchuk, P.B. Mitrofanov