

Получена: 15.09.2017 г.

Приета: 12.12.2017 г.

THE STEEL AND CONCRETE COMPOSITE CABLE SPACE FRAMES

G. Gasii¹

Keywords: module, composite, structure, cable, frame

ABSTRACT

New structures in relation to civil engineering with application of the newest construction materials using roof system of long-span buildings as an example are considered. The structures combine durability and reliability necessary for exploitation. Reliability of steel and concrete composite cable space frame is confirmed by experimental and theoretical researches. The steel and concrete composite cable space frames are the results of synthesis of structural, cable, steel and concrete elements, and consist of spatial composite modules, acquired through their advantages and peculiarities, which determine their efficiency. These structures were designed by the author and have been patented.

The purpose of the study is to present the types of the steel and concrete composite cable space frames in particular to cover halls, hangars for aircraft and other vehicles, garages for a large machinery, large-span buildings and structures of airports, etc.

The newness of the steel and concrete composite cable space frames lies in both the effective application of the properties of the materials and the constructive concept.

1. Introduction

Development of an infrastructure of cities needs modernization, changes or rebuilding of existing structures and construction of new modern and original buildings. Structures that completely satisfy the demanding requirements of buildings are a combination of steel space trusses, steel cables or bars and slabs that are used not only to cover or protect from aggressive

¹ Grigorii Gasii, PhD student, 24 Pershotravnevyi Avenue, Poltava 36011, Ukraine,
e-mail: grigoriigm@gmail.com

external factors, rain, snow and other atmospheric influences, but are also used as bearing elements.

These composite structures were designed with the participation of the author at the Department of Metal, Wood and Plastic Structures of the Poltava National Technical Yuri Kondratyuk University (Poltava city, Ukraine) and were patented. They are called Steel and Concrete Composite Cable Space Frames.

2. Structural concept of the steel and concrete composite cable space frame

The purpose of the study is to present the new kind of spatial composite structure made of modern and strong materials for civil construction in particular of cover halls, hangars for aircraft and other vehicles, garages for large machinery, large-span buildings and structures of airports, etc.

Novelty of the steel and concrete composite cable space frame lies in effective application properties of materials [1]. It means that the steel members are mainly in tension, and the concrete members are in stress. The steel and concrete composite cable space frame is a double-layer structure that consists of the three different kinds of structural elements: top chord, steel space trusses and bottom chord (Fig. 1). The steel space trusses are made of segments of steel tubes or rods. The top chords are made of reinforced concrete slabs. The elements of the bottom chord are made of steel cable, so these elements can be only in tension.

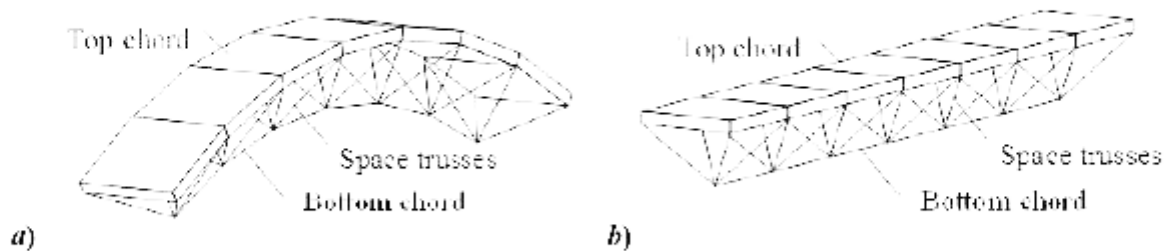

Figure 1. The steel and concrete composite cable space frame:
a) arched element; b) beam element

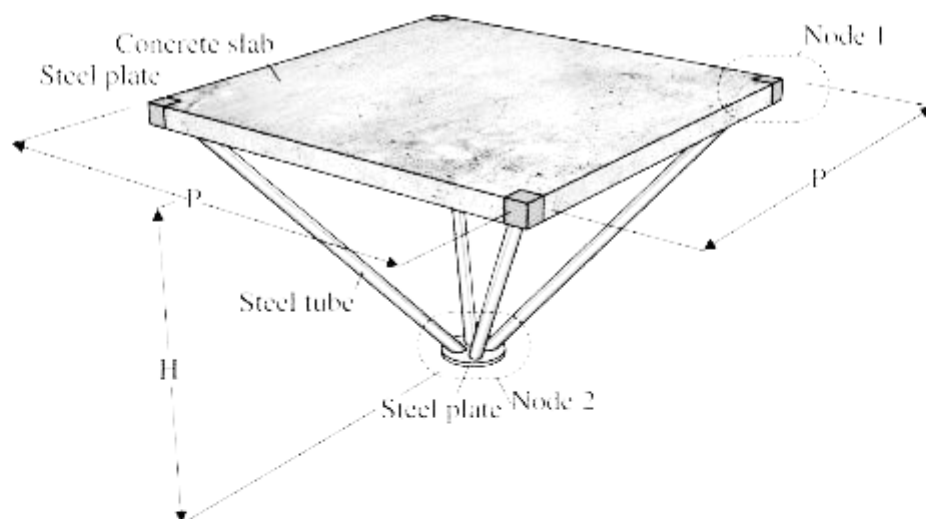

Figure 2. The steel-concrete space units of the steel and concrete composite cable space frame

The steel and concrete composite cable space frame is assembled on the construction site from steel-concrete space units (Fig. 2) and the bottom chords (Fig. 3).

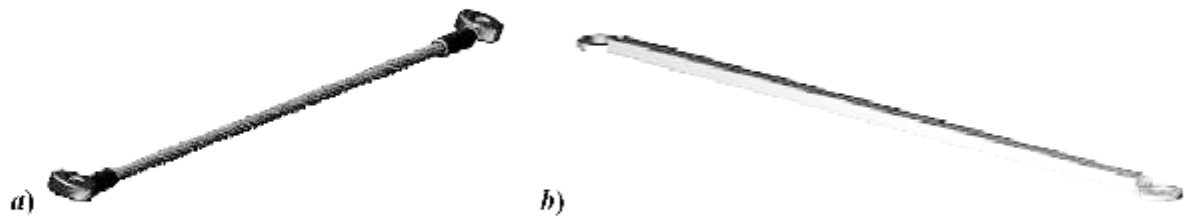

Figure 3. The bottom chords:
a) in cable case; b) in rod case

The structural members are routinely joined at node 1 and node 2 (see Fig. 2) by bolted connections designed by the author [2] (Fig. 4), but sometimes in specific cases can be joined by welded connections (Fig. 5).

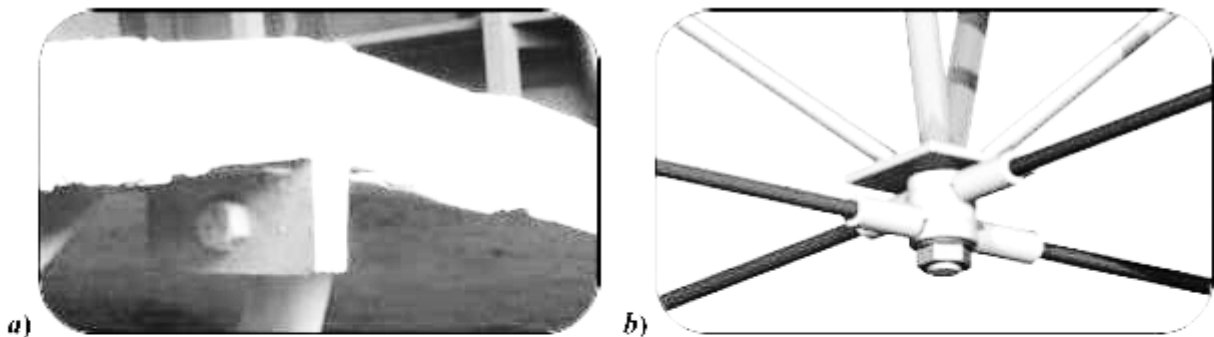

Figure 4. Bolted connections:
a) node 1; b) node 2

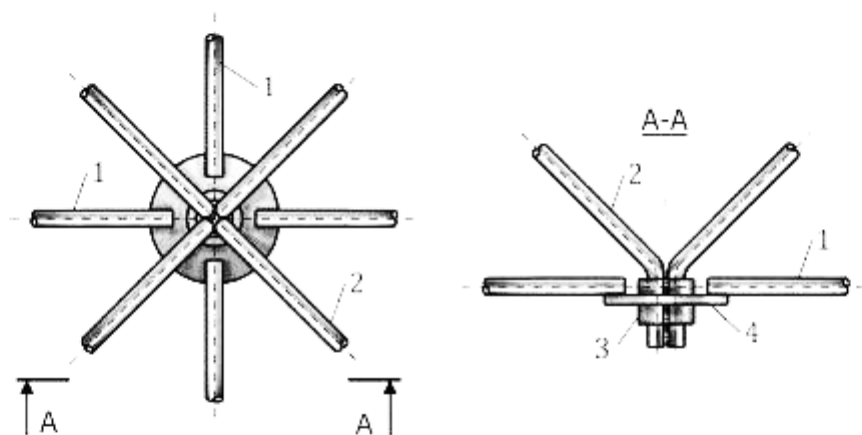

Figure 5. Welded connection (node 2):
1 – flexible rod; 2 – rod; 3 – coupling; 4 – steel round plate

Besides, node 1 and node 2 can have different designs depending on the forces that appeared in the structural members [2].

The choice of a connection type (node 1 and node 2) routinely depends on the function of the buildings, their span and shape, but preference is given to bolted connections because they are easier in assembling and are able to carry the high loads that typically appear in structural members of civil structures. The steel and concrete composite cable space frame can have various shapes and contours (Fig 6).

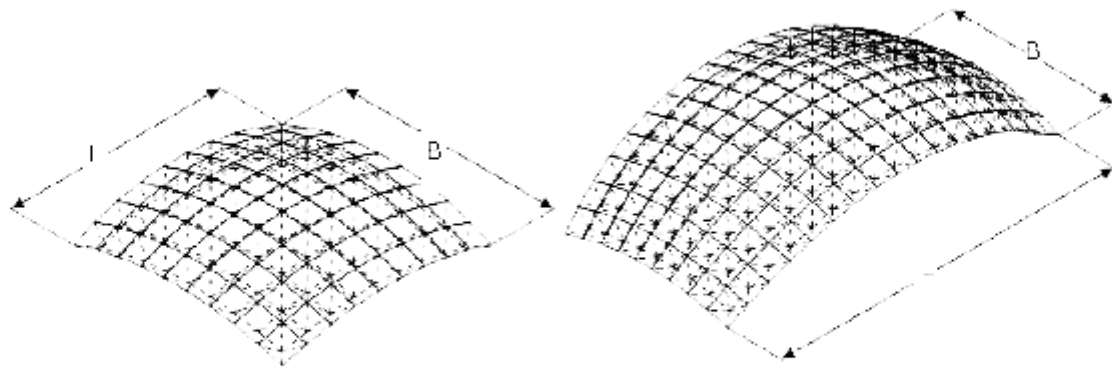

Figure 6. Shapes of the steel and concrete composite cable space frame

Curvature of the structure is achieved by changing length L of the bottom chord. The length of the segments of the bottom chord depend on angle α and the size of the slab P (Fig. 7).

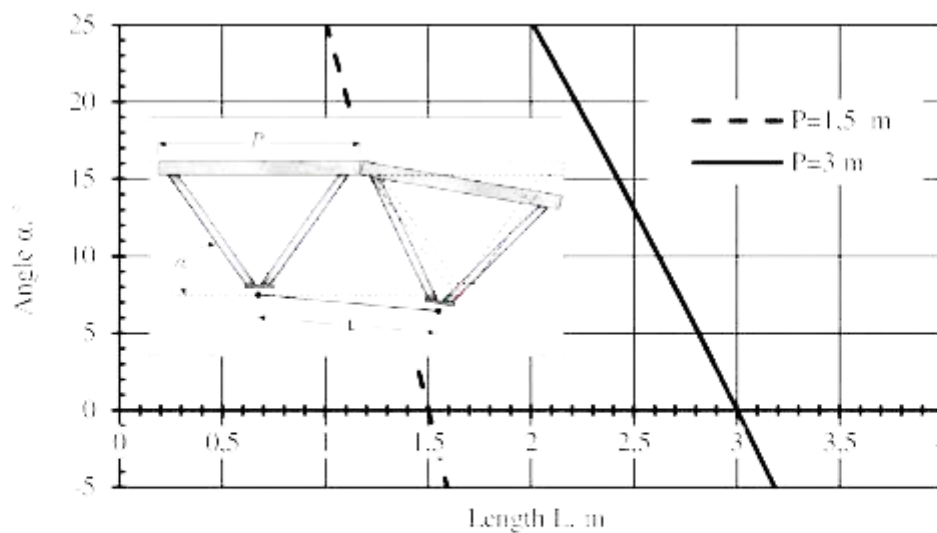

Figure 7. The length determination of the bottom chord of the steel and concrete composite cable space frame

The steel-concrete space units are used for assembling various structures including flat double-layer grids, single-span shells, etc. [3, 4]. Distances that are covered with these structures reach 100 m. The steel and concrete composite cable space frame can also be used to assemble cantilever covers for small-span areas. In general, the curvature of the steel and concrete composite cable space frame depends on constraints. If the structure is fixed or pinned from both sides, the angle α is limited, but if it has roller connection, at least from one side, the angle α can be as shown in Fig. 7 [5].

3. The main points of shaping of the steel and concrete composite cable space frame

There is a need to find effective structural systems including shells in today's conditions of the development of scientific and technological advances and the growth of social needs. The main requirements imposed on shells or its parts except reliability and the required bearing capacity are an architectural view, aesthetics, ergonomics and high indicators of efficiency.

Using reliable and modern materials to design the new structural concept is an important issue. Steels, modern concretes with various fillers and composites belong to the materials that meet the stated requirements.

The effectiveness of the developed structures depends on the usage of these materials and their conditions of behavior, which means that materials need to be under pressure of the forces, which they resist well, i.e. steel needs to be used in stretched or compressed elements and concrete needs to be used in compressed. Considering this, the steel and concrete composite cable space frame is promising direction of building structures.

In [6] kinds of steel and concrete composite cable space shells are proposed and developed, and their main advantages and design features revealed. As a result, the new efficient structures of shells used for covering large-span buildings and areas are proposed.

Developed steel and concrete composite cable space shells are implemented in industrial and civil construction. Applications developed for the designs of large-span constructions covering objects provide a significant economic benefit through the efficient use of materials [7].

4. Technical and economic characteristics of the steel and concrete composite cable space frame

There is a problem with the excessive laboriousness and material consumption, which appears in consequence of the not rational use of materials in construction. These factors have direct impact on the overall cost and duration of the project implementation. That is why there is a need for new constructions with structural concepts, which will largely make it possible to save materials and reduce complexity of construction. These structures are the steel and concrete composite cable space frames. The steel-concrete composite structure is used for creating the new construction because this material is reliable, has been studied well and is used very widely in various fields of construction [8 – 19]. The essence of the steel and concrete composite cable space frame lies in the rational and efficient use of materials and the behavior of structural elements.

The purpose of study is to calculate the technical and economic parameters of the steel and concrete composite cable space frame and the validity of feasibility of using them in different buildings and structures.

The results of previous studies show that the steel and concrete composite cable space frame combine the advantages of space frame, reinforced concrete and cable structures [13]. The effectiveness of the structural concept and optimal geometric dimensions have been found [14]. The steel and concrete composite cable space frames are reliable and have nice aesthetic appearance due to original spatial shapes and outlines. Therefore, it is necessary to prove the effectiveness of the steel and concrete composite cable space frame so that we can increase the interest and their implementation in the real sector of the construction.

It is necessary to perform the calculation of the technical and economic parameters and to assess the advantages of the new construction compared with the existing analogues to determine the scope of the steel and concrete composite cable space frame. A cell of a roof of a one-story industrial building with a span of 30 m and 12 m column step has been taken for comparative analysis. Firstly, the analysis of the weight has been conducted between the steel and concrete composite cable space slab (CC slabs) and typical series of reinforced concrete slabs, which are widely used in Ukraine.

The slabs that have been compared are designed for load within 200 – 300 kg/m², therefore the ratio of the weight slabs to their bearing capacity was determined for a more objective assessment of effectiveness of the design.

It has been found out that the steel and concrete composite cable space slab is more effective than a typical series of concrete slabs at 30 – 66% with the same load capacity (Fig. 4).

After this, a comparison has been made between the complexity of the roof structure made of a steel and concrete composite cable space slab and typical reinforced concrete structures.

The studies show that the use of the spatial grid-cable steel-concrete composite slab allows reducing the weight of the roof by 24 – 65%, the man-hour by 7.6% and the machine-hour by 35.5% in comparison with existing analogues [7, 8].

In addition, to find the technical benefits in the compared reinforced concrete shell, numerical investigation has been conducted. In both cases, for the steel and concrete composite cable space frame and the reinforced concrete shell, the same boundary conditional (for Fig. 8 it is four pinned support, and for Fig. 9 is pinned along the perimeter) has been used. The load is 2 kN/m². Both the top chord of the steel and concrete composite cable space frame and the reinforced concrete shell have been modeled as a three-layer element. The modeling is conducted in plastic. Materials are modeled by real stress-strain curves (Fig. 10). In Fig. 10 the red line AB shows material in tension.

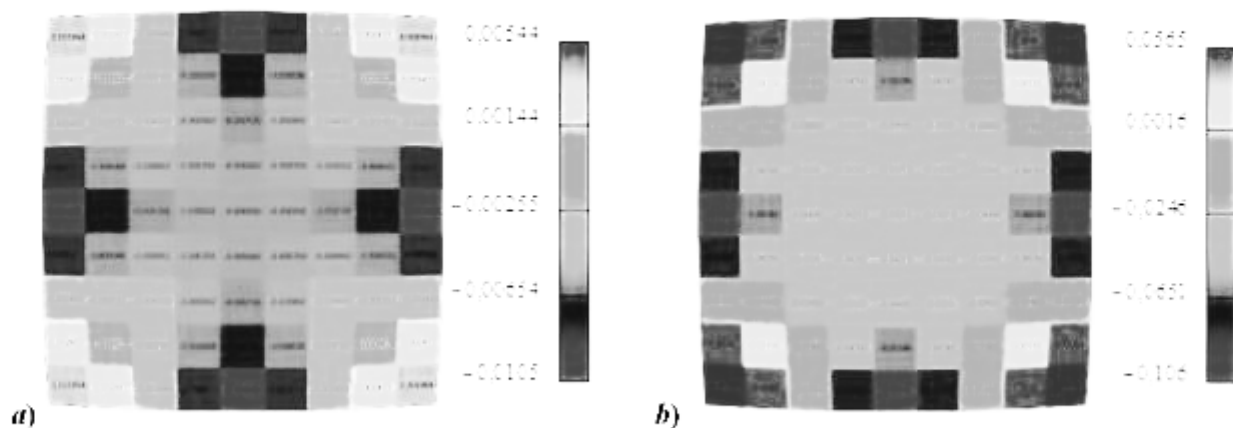

Figure 8. Vertical displacement (m):

a) the steel and concrete composite cable space frame; b) reinforced concrete shell

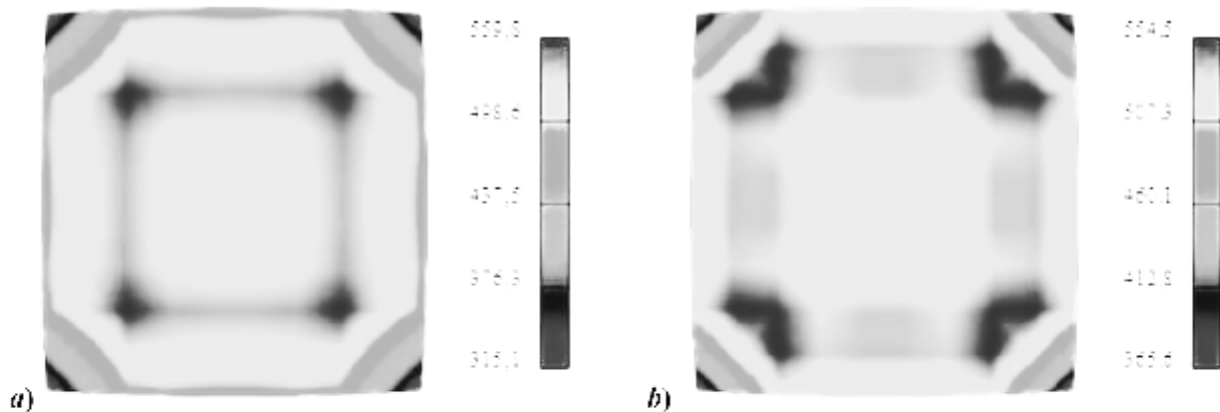

Figure 9. Plate VonMises stress (MPa):

a) the steel and concrete composite cable space frame; b) reinforced concrete shell

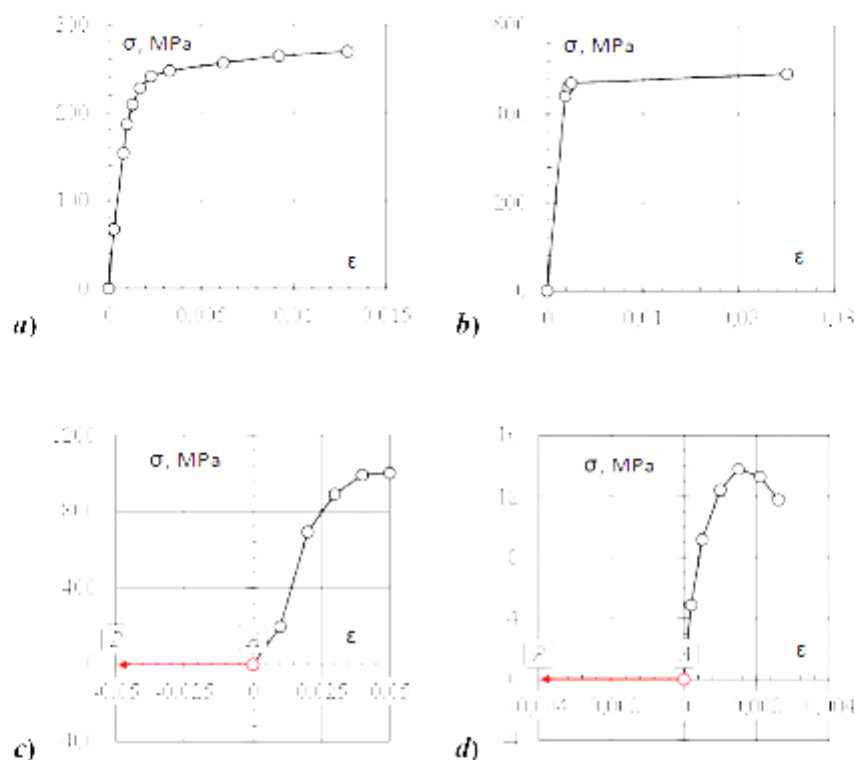

Figure 10. The stress-strain curves:

- a) steel tube σ 159 \times 3,5 mm [15]; b) reinforcement [16];
c) steel cable [17]; d) concrete [16]*

As we can see (Fig. 8 and Fig. 9) the steel and concrete composite cable space frame has better technical characteristics than reinforced concrete shell. As shown in Fig. 8 and Fig. 9, the vertical displacement of the steel and concrete composite cable space frame is lesser than the vertical displacement of the reinforced concrete shell with 85%, and the stress of the top chord of the steel and concrete composite cable space frame is lesser than the stress of the reinforced concrete shell with 15%.

5. Manufacturing and construction of the steel and concrete composite cable space frame

Production of steel-concrete space units can be performed in the plants that produce steel building structures, and other plants that have the equipment for processing steel and concrete casting of products. Technologies of processing, assembly, welding, loading and unloading of steel structural member of the composite steel and concrete grid-cable constructions are similar to the technology of production of conventional steel structures and concrete structures. Manufacturing technology of the steel and concrete composite cable space frame is divided into two separate processes: fabrication of a steel lattice (frame) and the making of slab. Construction of the steel and concrete composite cable space frame is performed by the methods described in [18, 19]. During the design of the steel and concrete composite cable space frame there is a task to get rid of the disadvantages of steel and concrete elements. The question concerning the choice of strength grade of concrete, steel tubes grade, and acceptance of reinforcement ratio is of great importance [18].

Basic materials for manufacturing of such support system are concrete and steel tubes. Heavy concrete of the following project classes B12.5; B15; B20; B25; B30; B40; B45 should be applied. Steel electric-welded tubes should be used [18].

Conclusions

The steel and concrete composite cable space frames are the new kind of large-span structures, which have advantages: in particular, they are lighter and have lower complexity both in manufacturing and assembling than analogues. The steel and concrete composite cable space frames consist of bottom chords and steel-concrete space units, which combine slabs and rods. This structural concept makes it possible to save materials due to their rational use. The conclusion that this type of constructions is more reliable and efficient in exploitation (30 – 66%) than analogues allows to save materials up to 24 – 65%, which is obtained thanks to experimental, theoretical and analytical studies as well as the stress-strain state numerical investigation.

The idea of the steel and concrete composite cable space frames is to obtain high strength characteristics and technical and economic benefits due to the combination of effective structural solutions. Also, what lies on the basis of the steel and concrete composite cable space frames is the principle of modularity of elements, i.e. the use of repeatedly repeated constructive elements of complete factory-made.

In conclusion, it should be noted that the steel and concrete composite cable space frames have different forms and shapes. This allows using structures successfully in the construction of buildings and different structures.

REFERENCES

1. *Gasii, G. M.* Types of Steel and Concrete Composite Cable Space Frames. Science and Transport Progress. Bulletin of Dnipropetrovsk National University of Railway Transport, (6), 158-165, 2016. DOI: 10.15802/stp2016/90514.
2. *Gasii, G. M.* The Flat Double-Layer Grid-Cable Steel-Concrete Composite. In METNET Annual Seminar in Castellon, Spain, on 11–12 October 2016, 56-62, 2016.
3. *Gasii, G. M.* The Main Points of Form Finding and Designing Structure Systems from the Steel-Concrete Grid-Cable Composite Constructions. Construction, Materials Science, Mechanical Engineering, (87), 48-53, 2016.
4. *Storozhenko, L. I., H. M. Hasii.* The New Composite Designs for Mine Tunnel Support. Scientific Bulletin of National Mining University, (4), 28-34, 2015.
5. *Storozhenko, L. I., G. M. Gasii.* Composite Steel and Concrete Large-Span Constructions for Airport Structures. Proceeding the Seventh World Congress «Aviation in the XXI-st century» – «Safety in Aviation and Space Technologies», Kyiv, Ukraine, September 19–21, 2016, 10.1.22–10.1.26, 2016.
6. *Storozhenko, L. I., G. M. Gasii.* The Features of Structural Concept and Designing of the Full-Length Experimental Module of the Composite Steel and Concrete Grid-Cable Roof. Academic journal. Industrial Machine Building, Civil Engineering, 1(46), 51-59, 2016.

7. *Gasii, G. M.* Comparative Characteristics of the Spatial Grid-Cable Steel-Concrete Composite Slab. *Academic Journal of Lviv Polytechnic National University. Series "Theory and Building practice"*, (844), 260-265, 2016.
8. *Gasii, G., Hasii, O., Zabolotskyi, O.* Estimate of Technical and Economic Benefits of a New Space Composite Structure. In *MATEC Web of Conferences*, 116, 02014, 2017.
9. *Oehlers, D. J., M. A. Bradford.* Composite Steel and Concrete Structures: Fundamental Behaviour: Fundamental Behaviour. Elsevier, 588, 2013.
10. *Johnson, R. P.* Composite Structures of Steel and Concrete: Beams, Slabs, Columns, and Frames for Buildings. John Wiley & Sons, 252, 2008.
11. *Gasii, G. M.* Technological and Design Features of Flat-Rod Elements with Usage of Composite Reinforced Concrete. *Metallurgical and Mining Industry*, (4), 23-25, 2014.
12. *Storozhenko, L. I., G. M. Gasii.* Experimental Research of Strain-Stress State of Ferrocement Slabs of Composite Reinforced Concrete Structure Elements. *Metallurgical and Mining Industry*, (6), 40-42, 2014.
13. *Storozhenko, L. I., G. M. Gasii., S. A. Gapchenko.* The New Composite and Space Grid Cable-Stayed Constructions. *Academic journal. Industrial Machine Building, Civil Engineering*, 1(40), 91-96, 2014.
14. *Gasii, G. M.* Experimental Studies of Structural-Guy Rope Coverings. *Academic journal. Industrial Machine Building, Civil Engineering*, 3(42), 47-51, 2014.
15. *Demchenko, O. V.* Stress-Strain State of Centrally Compressed Elements of Tube-Concrete with Nuclei of High-Strength Concrete, 163, 2015.
16. *Yurko, P. A.* The Strength of Normal Sections of Compressed Concrete Elements on the Basis of Deformation Model, 194, 2016.
17. *Dhakar, S., et al.* Experimental, Numerical and Analytical Modelling of a Newly Developed Rockfall Protective Cable-Net Structure. *Natural Hazards and Earth System Sciences*, 11, 3197-3212, 2011.
18. *Storozhenko, L. I., G. M. Gasii, S. A. Gapchenko.* The Composite Steel and Concrete Grid-Cable Space Structures: Monograph, Poltava: «ASMI», 218, 2015.
19. *Gasii, G. M.* Production of Full-Scale Experimental Modular Specimens of the Steel and Concrete Composite Cable Space Frame. *Inżynieria Bezpieczeństwa Obiektów Antropogenicznych*, 3-4, 13-17, 2017.